

Percussion 101 Refresher

**American Band
College**

2013

Presented by Jim Catalano

A Percussionist is....

A musician that plays it all:

- Battery (Drums)
- Tuned Percussion
 - Timpani
 - Mallet Keyboard Instruments
- Accessory Percussion
- World Percussion

TOTAL PERCUSSION



Percussion Products

- Combo
 - Drum Sets
 - Snare Drums
- Accessories
 - Drumheads
 - Drumsticks
 - Mallets
 - Hardware (Stands)
 - General Accessories
 - Cases, Bags & Covers
- School / Concert
 - Marching Drums
 - Concert Snare Drums
 - Concert Bass Drums
 - Concert Toms
 - Timpani
 - Mallet Instruments
 - Educational Snare Drum & Bell Kits
 - Ethnic Percussion

Tools of a Percussionist

- Pencil w/ eraser
- Drum Key
- Dark towel or pad to place on music stand for sticks mallets and accessories
- Pitch Pipe or Tuning Fork - **Timpani Tuning**
- Practice Pad (**Rubber or Tunable**)
- Mallet Bag
- Sticks & Mallets

Sticks / Mallets

- Concert Drumsticks (Round bead)
- Drumset Drumsticks (Acorn shaped bead)
- Wire or Nylon Brushes
- Timpani Mallets (General & Staccato)
- Soft Yarn Mallets (Marimba, Vibes, Suspended Cymbal)
- Hard Rubber Mallets (Xylophone, Wood & Temple Blocks)

Percussion Mallet Pack

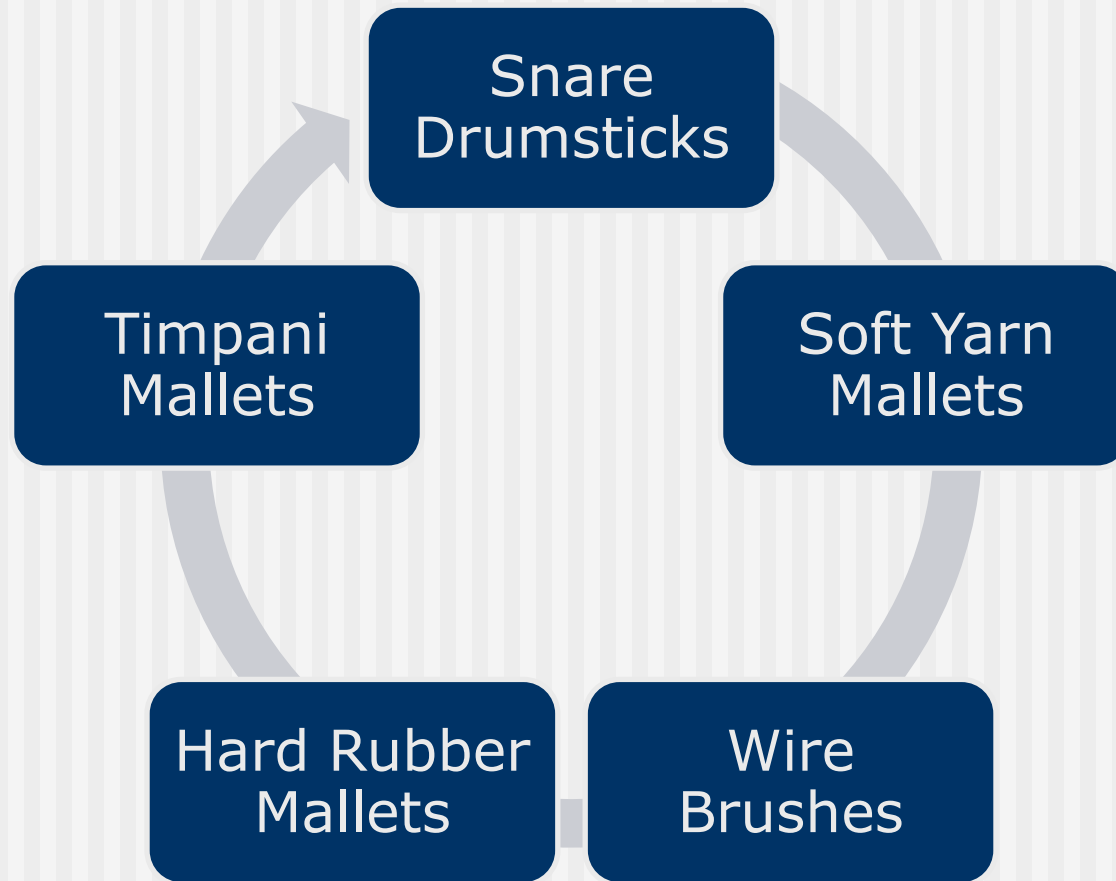

Educational Percussion

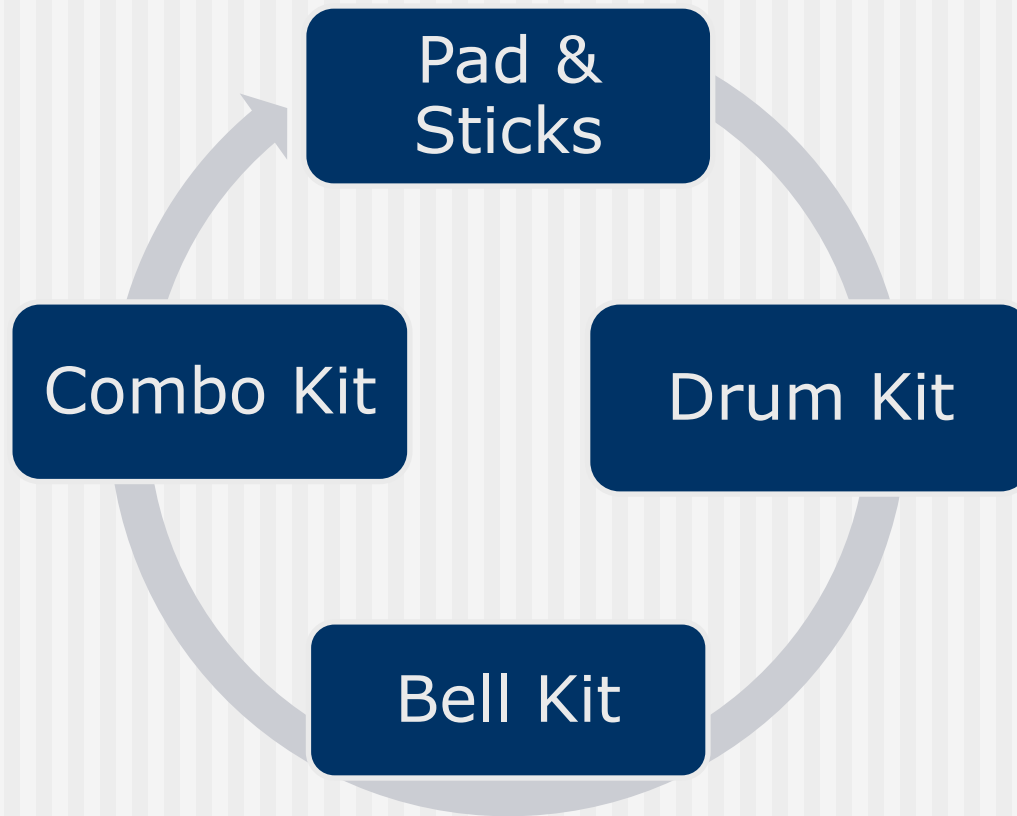

Educational Percussion Kits

Components in Bag / Case	Drum	Bell	Combo Drum/Bell
Snare Drum	X		X
2.5 Oct Bells		X	X
Snare Stand*	X		X*
Bell / Pad Stand*		X	X*
Practice Pad	Rubber	Tunable	Tunable
Drumsticks	X	X	X
Mallets		X	X

Drum Kit

- Compartmentalized Rolling Bag w/ Pull Handle
- 5x14" Snare Drum
- Rubber Practice Pad
- Stand
- Sticks



Bell Kit

- Compartmentalized Rolling Bag w/ Pull Handle
- 2.5 Oct. Aluminum Bells (F - C) w/ Note Names
- Tunable Practice Pad
- Stand for Bells & Pad
- Sticks, Mallets, Music Rack



Combo Percussion Kit

- Rolling Bag w/ Pull Handle
- 2.5 Oct. Aluminum Bells (F – C)
- 3.5x13" Snare Drum
- Tunable Practice Pad
- Combination Stand for Snare, Bells & Pad
- Sticks, Mallets, Music Rack

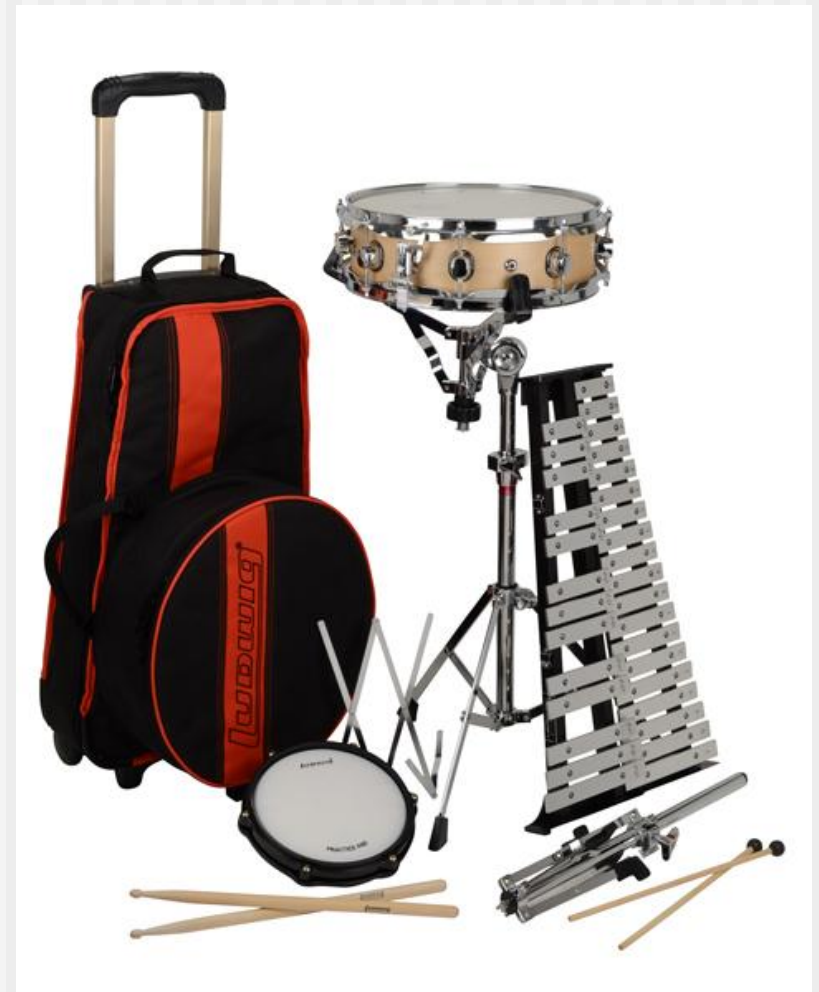

Practice Marimba

- 3 Octaves
- Paduak Bars
- Graduated Bars
- X-Frame Stand
- Rental
- Lightweight
- Portable
- Easy storage



Concert Snare Drums



3x13"

5x14"

6.5x14"

8x14"

Snare Drum Diagram

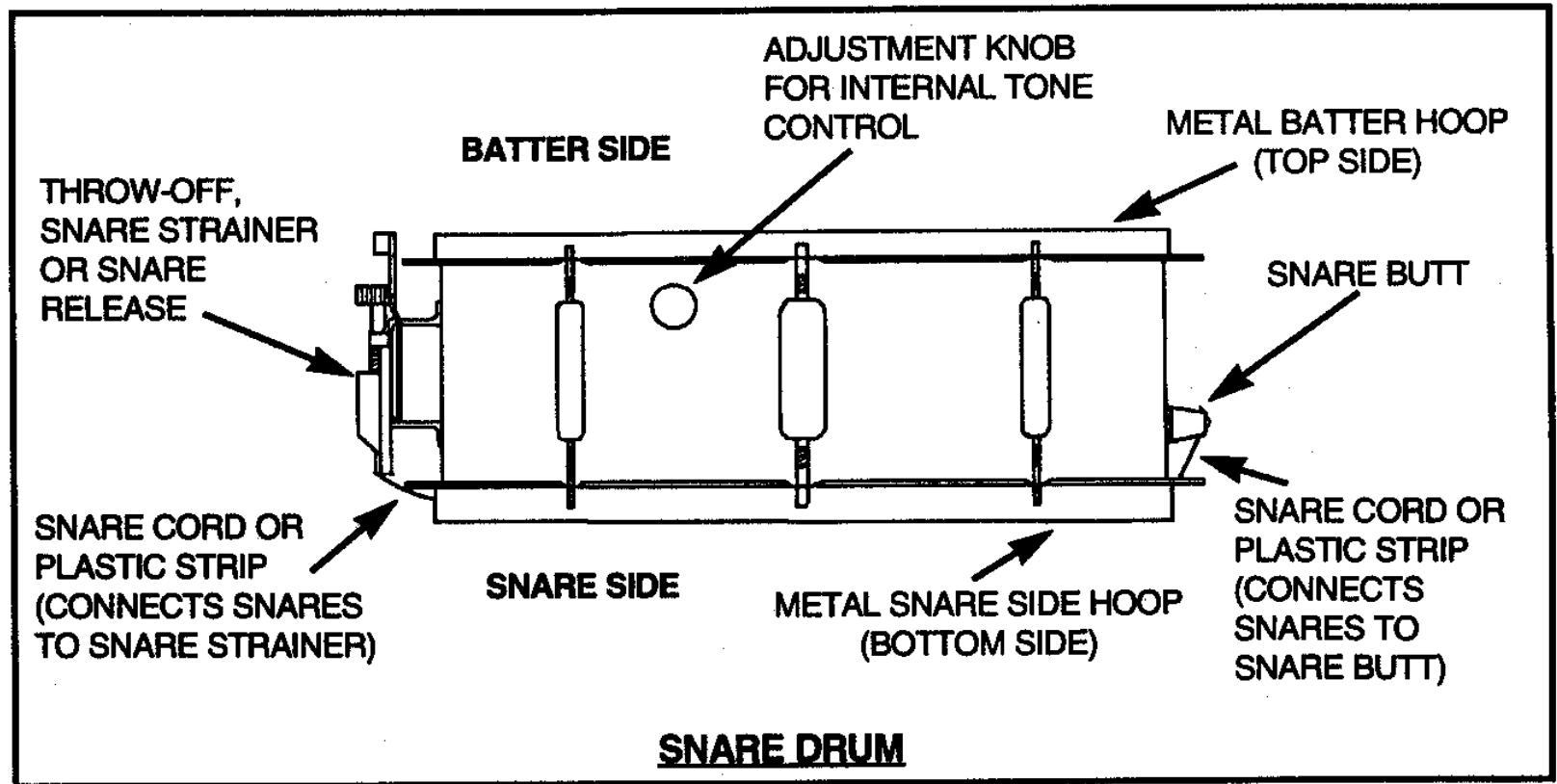
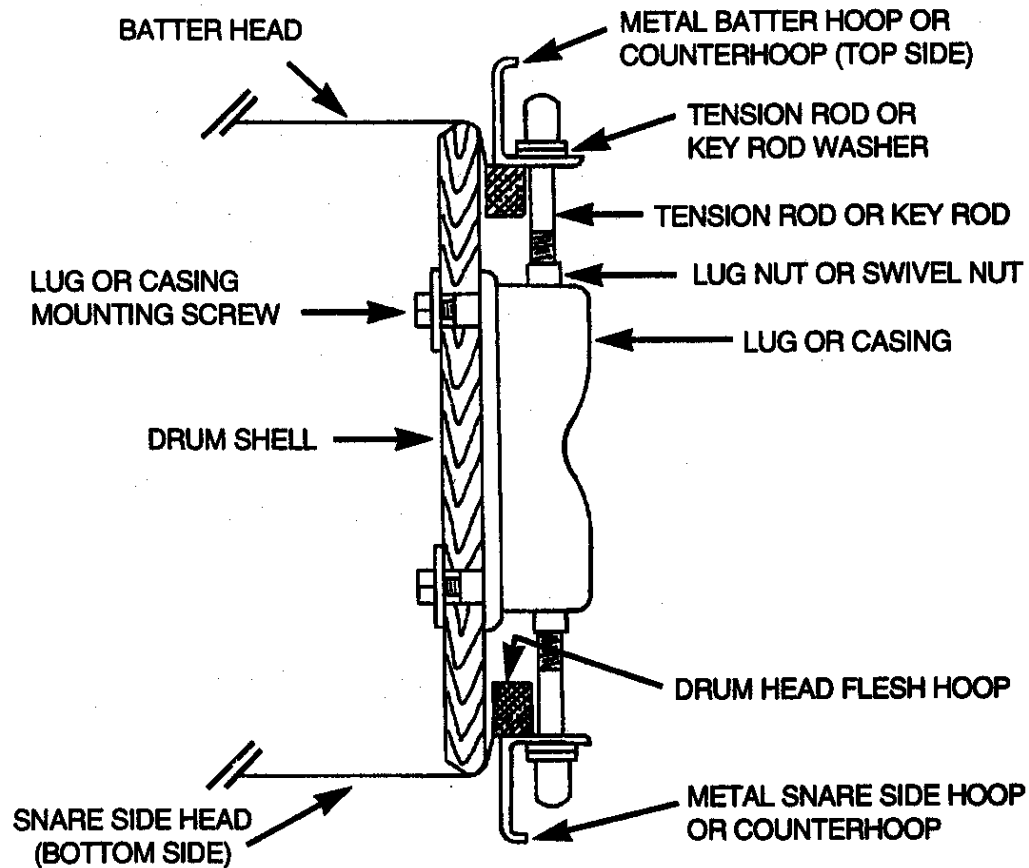

ILLUSTRATION 5

Drum Mechanics



TWIN LUG (DOUBLE END) ASSEMBLY FOR SNARE DRUM

Drum Playing Position

- Position
 - Level / Flat
 - Angled
- Height
 - Waist High
- Extended Height
Concert snare stand –
Essential for growing
students.

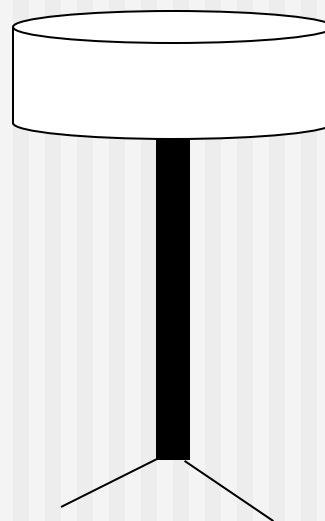

Flat

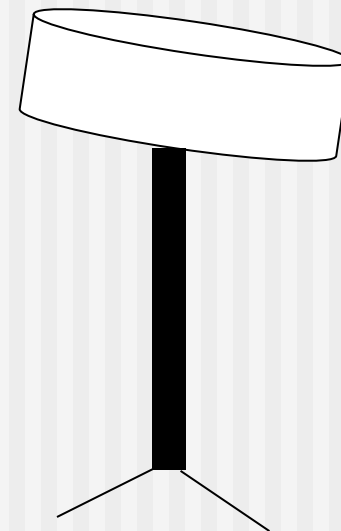

Angle

Snare Drum Heads, Sticks

- Head Changing
 - How to:
 - How often:
 - Watch for dents, stretching, clear spots
- Snare Strainer Tension
- Drumsticks (2B, SD1, Barrel shaped bead)
- Wire or Nylon Brushes

Snare Drum Tuning

Basic Tuning

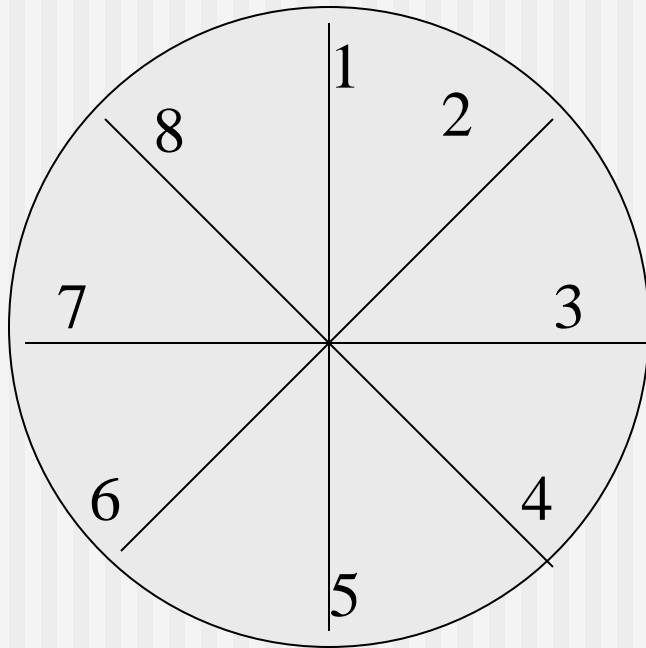

Cross Tuning – Fine Adjustment

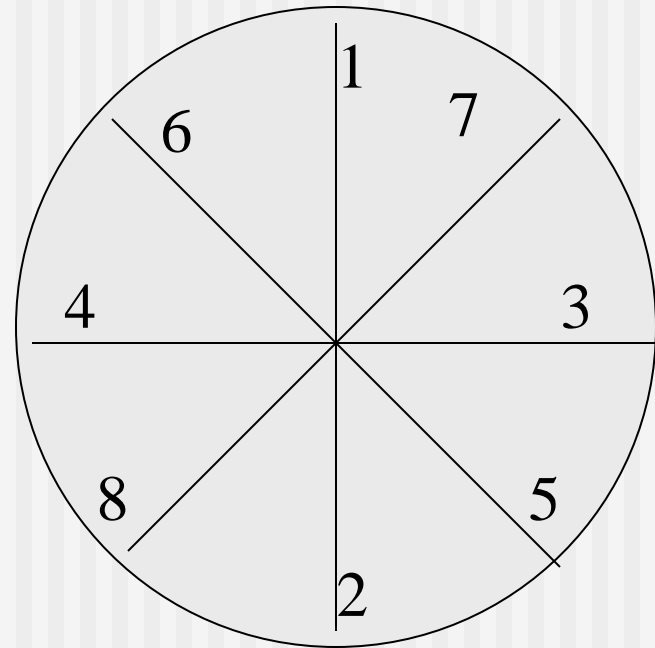

Crisp / Dry

Snare Drum Playing Area

- Striking Area

- Soft

- General

- Dry staccato

- Stroke

- Tap

- Rebound

- Bounce

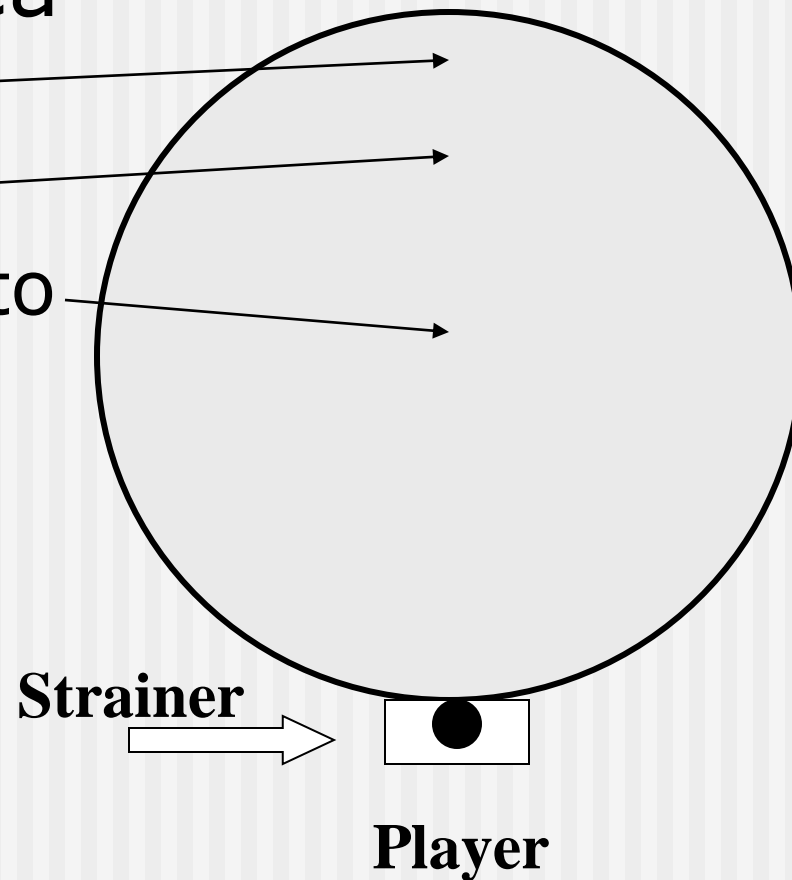

Snare Drum Grip / Position

- Grip
 - Traditional – (Great for jazz, marching)
 - Matched – (Universal for all percussion)
- Drum should not be tilted (Not necessary)
- Posture
 - Back straight & feet slightly spread
 - Top of drum height at waist level
 - Arms comfortably at side

Snare Drum Basics

- Tap
- Rebound
- Buzz (Multiple Bounce)

Foundation

4/4 R R R R | RLRLRLRL | RRRRRRRR

L L L L | LRLRLRLR | LLLLLLLL

The first system of notation consists of three measures. The first measure contains four quarter notes, each with a stem pointing down, and the letters 'R' and 'L' below them. The second measure contains eight eighth notes, grouped in pairs of four, with stems pointing down and alternating 'R' and 'L' letters below. The third measure contains eight eighth notes, grouped in pairs of four, with stems pointing down and 'R' and 'L' letters below.

RLRLRLRLRLRLRLRL | R

LRLRLRLRLRLRLRL | L

The second system of notation consists of two measures. The first measure contains sixteen eighth notes, grouped in four pairs of four, with stems pointing down and alternating 'R' and 'L' letters below. The second measure contains a single quarter note with a stem pointing down and the letter 'R' below, followed by a brace and a rest for the remainder of the measure, and the letter 'L' below.

Snare Rudiments

- Tap Patterns
- Roll Patterns
- Flam Patterns
- Diddle Patterns
- Drag Patterns

Slow to fast to slow

Soft to loud to soft

Snare Drum

- Rolls
 - Long Open Roll (RRLL)
 - Multiple Bounce (buzz w/ 16th note base)
- Grace Notes
 - Flam
 - Ruff
- Rim Shots (Many types)

Snare Roll Development

 - Multiple Bounce



R R R R etc.
L L L L etc.
R L R L etc.
L R L R etc.



R L R L etc.
L R L R etc.

Snare Roll Development

A musical staff in common time (C) showing a progression of snare rolls. It starts with a single eighth note, followed by two eighth notes, then four eighth notes, and finally two groups of eighth notes with sixteenth notes. The last two groups are marked with a 'z' and a bracket, indicating a specific rhythmic pattern.

RLRLR RLRLR etc.
LRLRL LRLRL etc.

A musical staff in common time (C) showing a progression of snare rolls. It starts with a single eighth note, followed by two eighth notes, then four eighth notes, and finally two groups of eighth notes with sixteenth notes. The last two groups are marked with a 'z' and a bracket, indicating a specific rhythmic pattern.

RLR LRL RLR LRL etc.
LRL RLR LRL RLR etc.

A musical staff in common time (C) showing a progression of snare rolls. It starts with a single eighth note, followed by two eighth notes, then four eighth notes, and finally two groups of eighth notes with sixteenth notes. The last two groups are marked with a 'z' and a bracket, indicating a specific rhythmic pattern.

RLRL LRLR etc.
LRLR RLRL etc.

Concert Toms

- Single headed
- Melodic pitched
- Tuned in minor 3rds
- Medium range
 - 10", 12", 13", 14"



Concert Bass Drum



- Available Sizes
 - 28" Diameter (MS)
 - 32" Diameter (MS)
 - 36" Diameter (HS)
 - 40" Diameter
- Stand
 - Cradle
 - Tilting / Suspended

Bass Drum

- 5% Tilt of bass drum on stand
- Drumhead Selection
 - Ludwig Weather Master Smooth White
 - Fiberskyn III Drumheads (Remo)
 - Calf-like, Darker and dryer sound
 - Renaissance Drumheads (Remo)

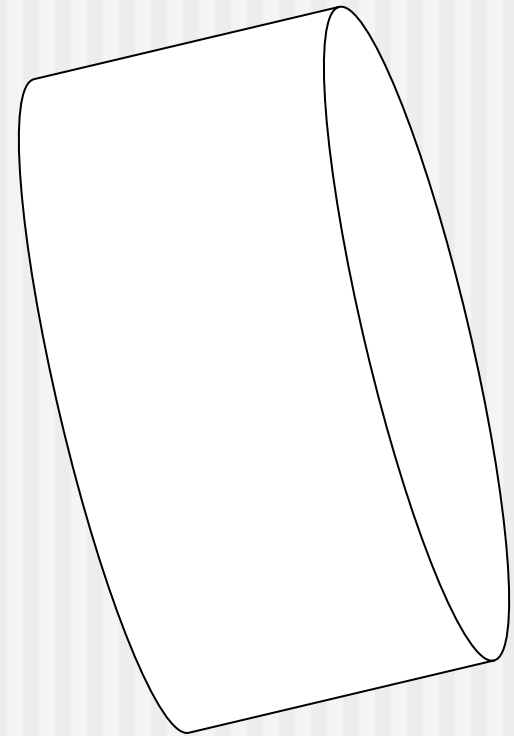

Bass Drum

- Tuning
 - Low fundamental – start loose and work tension up to clear low open sound
 - “Boom”
- Mallets
 - Soft (Special applications)
 - Medium (General playing)
 - Rollers (Pair)
- Anticipation (Watch the conductor)

Bass Drum

- Striking area of the bass drum
 - General
 - Dry staccato
 - Soft / Rolls
- Muffling / Dampening
 - Left hand
 - Knee

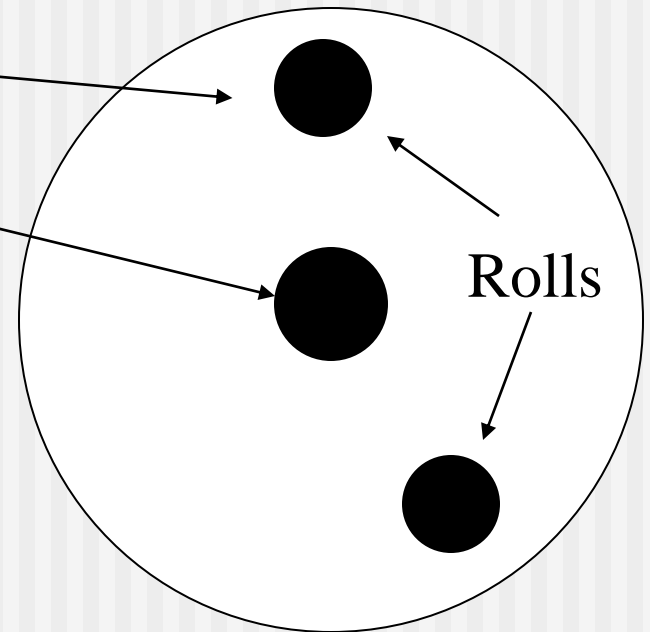

Cymbal Cradle

Hand Cymbals

Box Cradle for Cymbals

Height Adjustable Stand

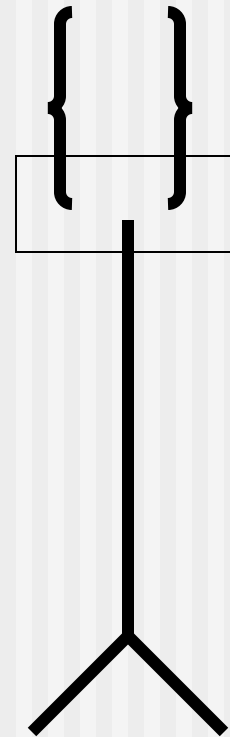

Hand Crash Cymbals

- 18" Medium Weight
- Cymbal cradle on stand
- Straps (pads???)
- Holding position
- Techniques
 - Glance (Flam)
 - Choke
 - Open crash

Suspended Cymbal

- Light weight 16" or 18"
- Mallet Selection
 - soft to medium yarn or cord
 - No timpani mallets, No Drumsticks, (except ride sound)
- Single stroke
- Roll technique
- Crescendo
- Anticipation
- Dampening

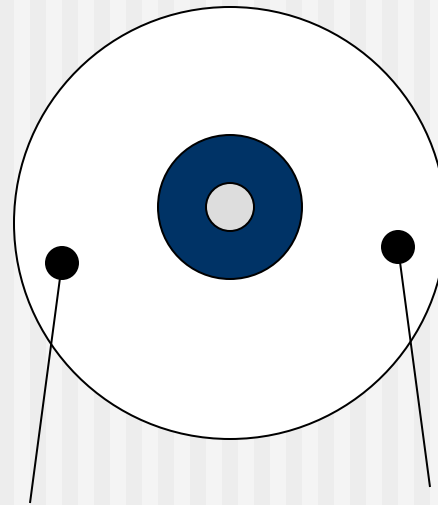

Suspended Cymbal

written:

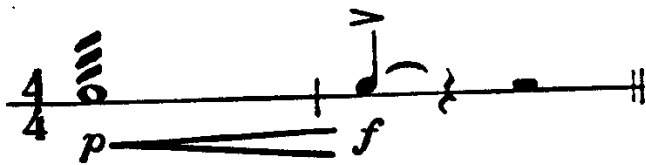

might be played:

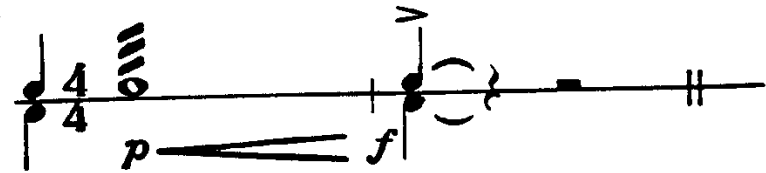

written:



might be played:

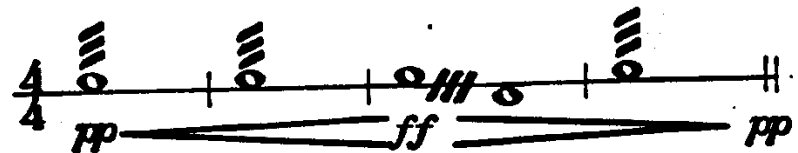

Finger Cymbals

- Quality of sound
 - Zildjian, Sabian,
- Holding style
- Striking technique
 - 90 degree angle
- Dampening
 - Body
 - Fingers
- Vibrato

Strike at right angles

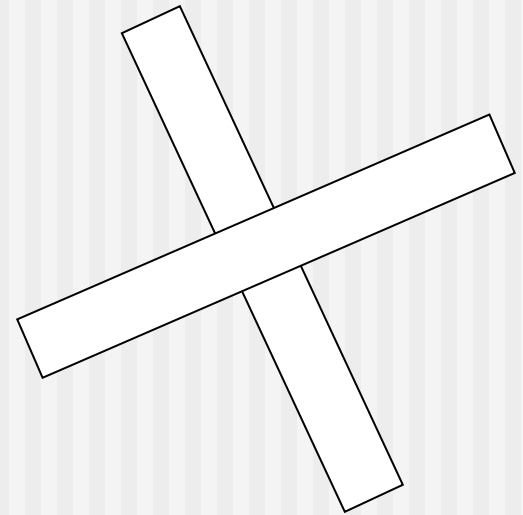

Hold high for projection

Tam Tam / Gong

- Gongs are tuned to a pitch
 - Various sizes
- Tam Tam is most common and has no definite pitch
- Tam Tam Stand must be sturdy
- Tam Tam Mallet must have weight

Tam Tam Technique

- Prime the Tam Tam
 - Lightly tap to start metal moving
- Pull Mallet Out of Tam Tam
- Muffling
 - Hands
 - Legs
 - Arms

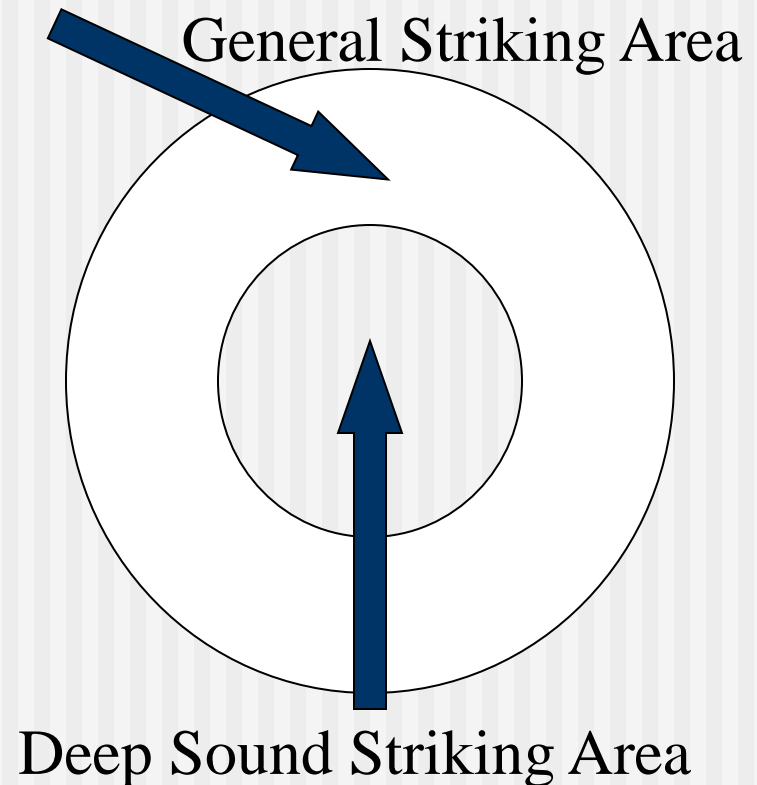

Tambourine

- Type
 - Headed (Calf or Goat Skin)
 - Headless
- Jingles
 - Single Row
 - Double Row
- Jingle Material
 - Brass, Copper, Silver, Combination, Metal
- Quality Tambourines
 - Black Swamp
 - Grover

Tambourine

- Technique
 - Avoid extraneous jingle sounds
 - Shake roll
 - Crescendo roll
 - Thumb roll
 - Knee / Fist
 - Fingers with one hand
 - Fingers with two hands, Tambourine on knee

Slow / Loud Technique

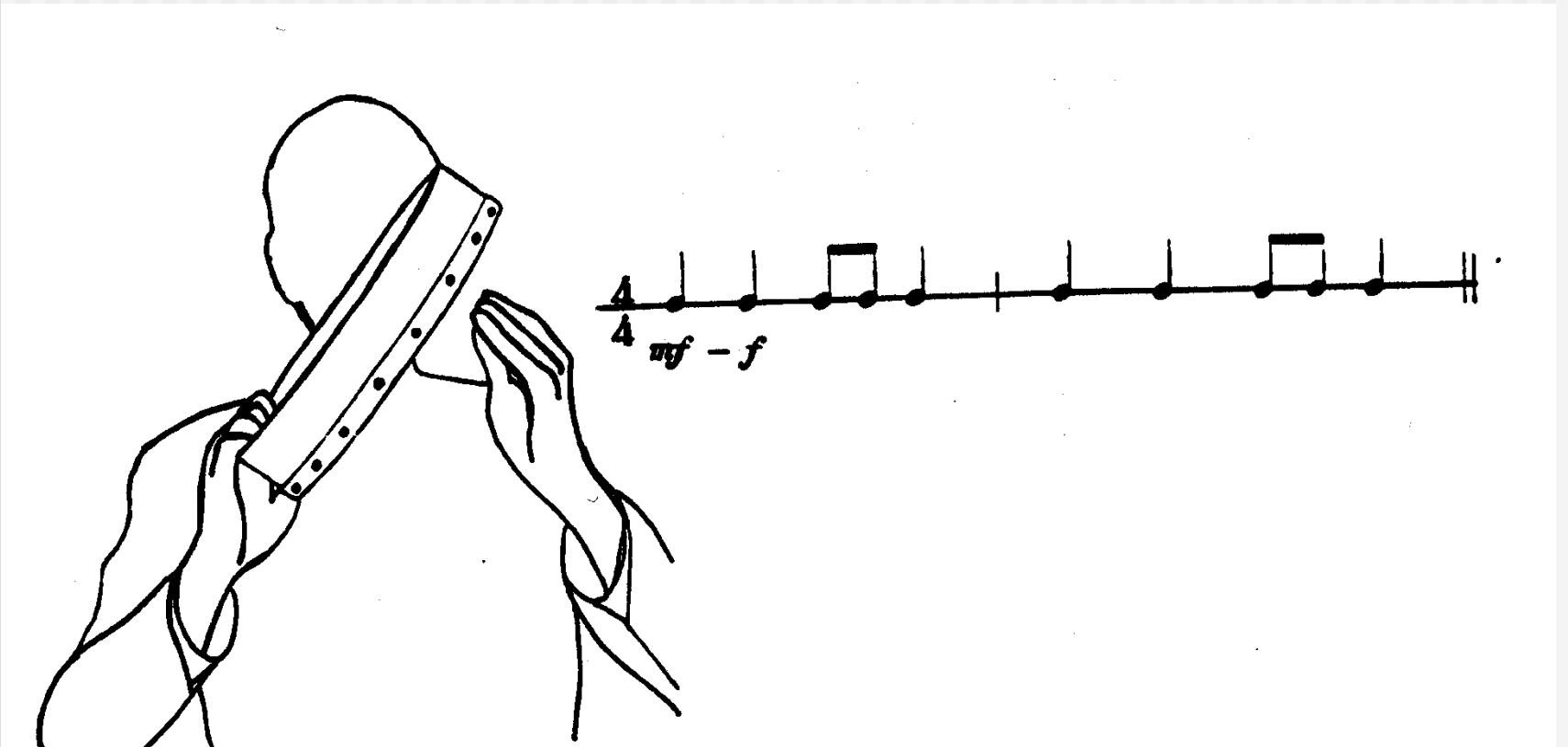

Slow / Soft Technique

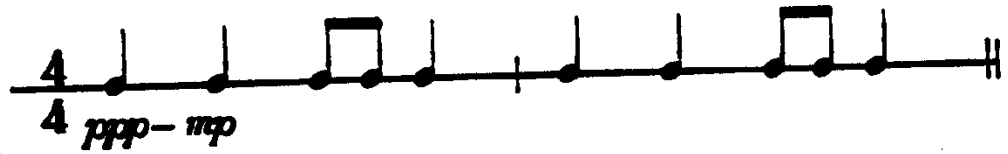
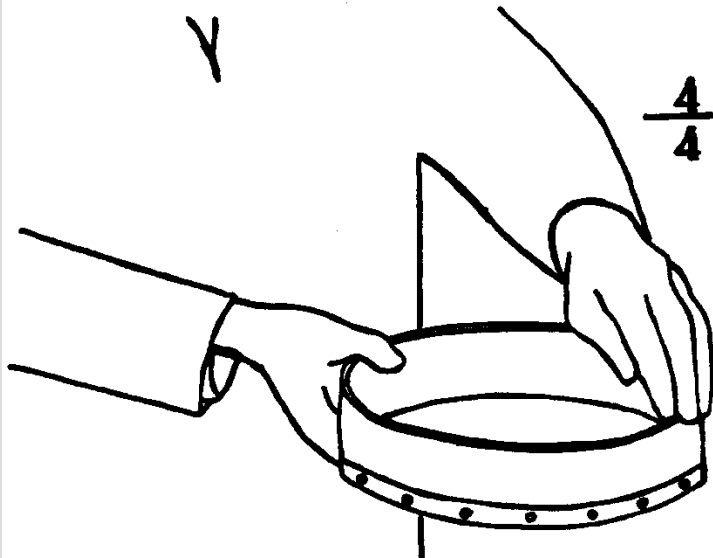

Fast / Loud Technique

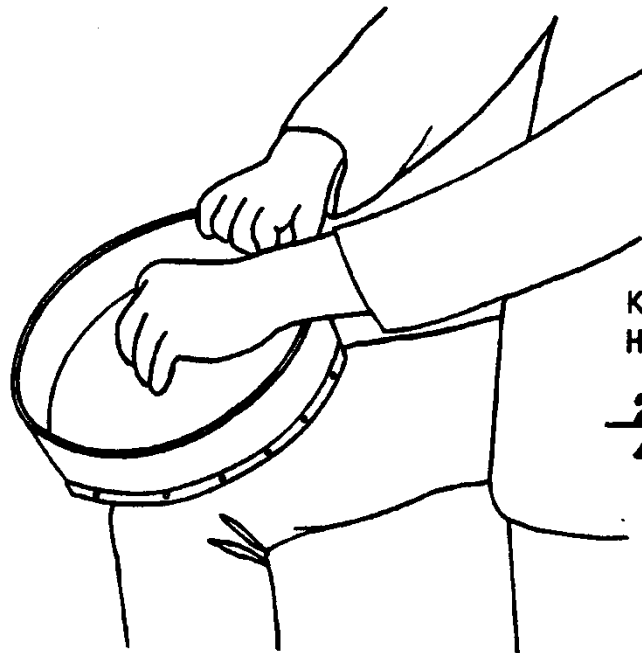

K = Knee
H = L.H.

$\frac{2}{4}$ *mf - ff*

A musical staff in 2/4 time showing a drum pattern. The pattern consists of two measures. The first measure contains a sequence of notes: K, H, K, H, K, K. The second measure contains a sequence of notes: K, H, K, H, K, K. The notes are represented by stems with flags, indicating eighth notes. The first measure has a double bar line above it, and the second measure has a double bar line above it. The dynamic marking *mf - ff* is written below the first measure.

Fast / Soft Technique

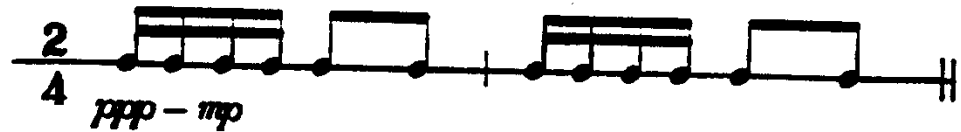
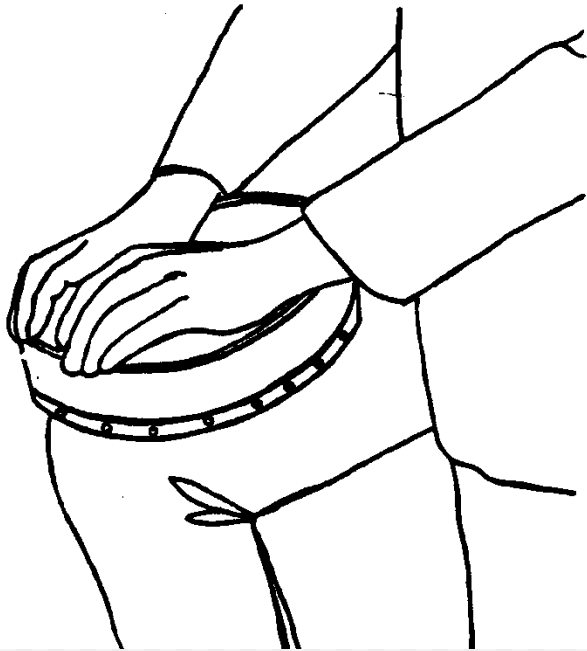

Triangle

- Product
 - 4", 6" or 8" Triangle
 - Beaters – Variety of diameters & weights
 - Triangle Clip
 - Makers: (Abel, Grover, Black Swamp)
- Holding position
 - In hand
 - On stand

Triangle Holding Position

Triangle Clip

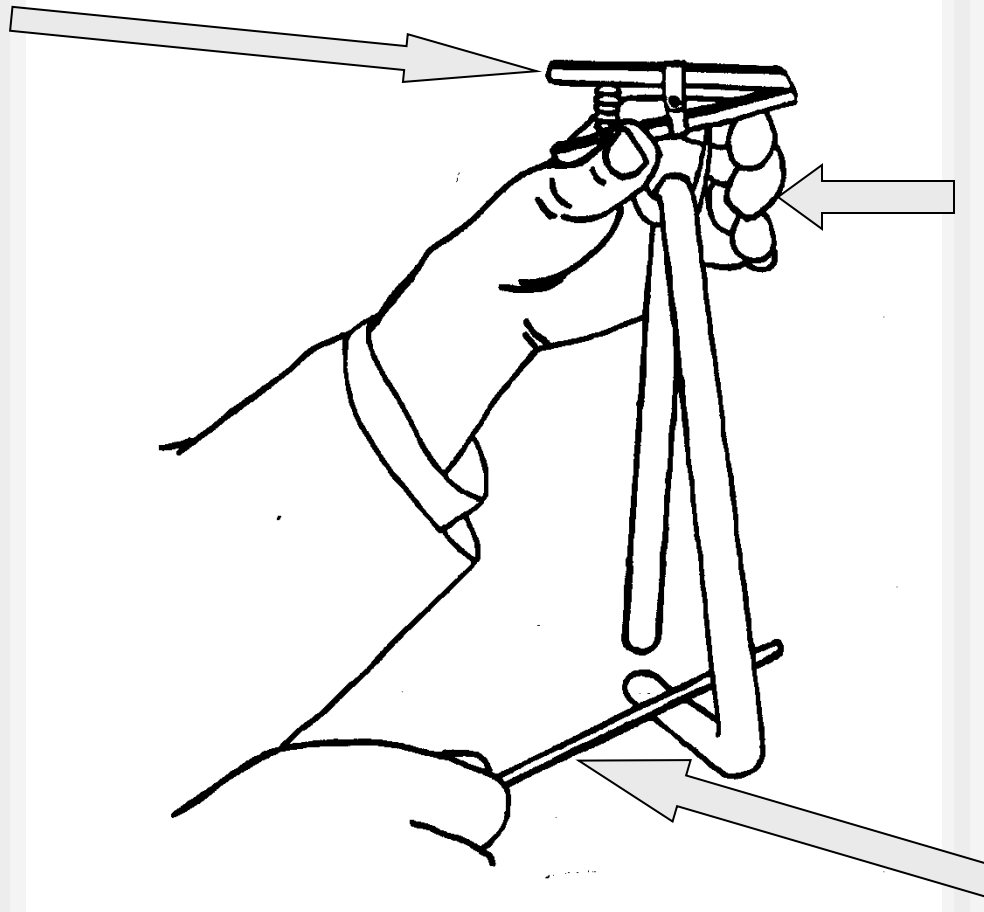

C Position
Of Hand

Hold high
maximum
projection

Little Fingers
Used to
Muffle

Striker

Triangle

- Striking area
 - Dark sound
 - Bright sound
- Single strokes
- Rolls
 - One hand
 - Two hand
- Muffling

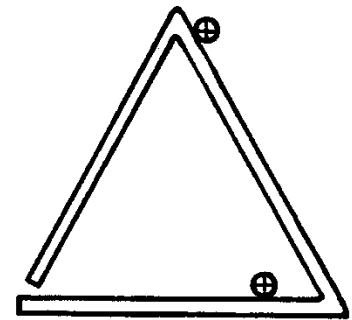
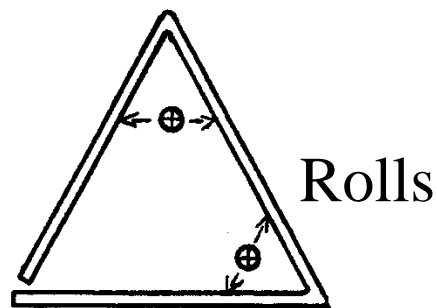
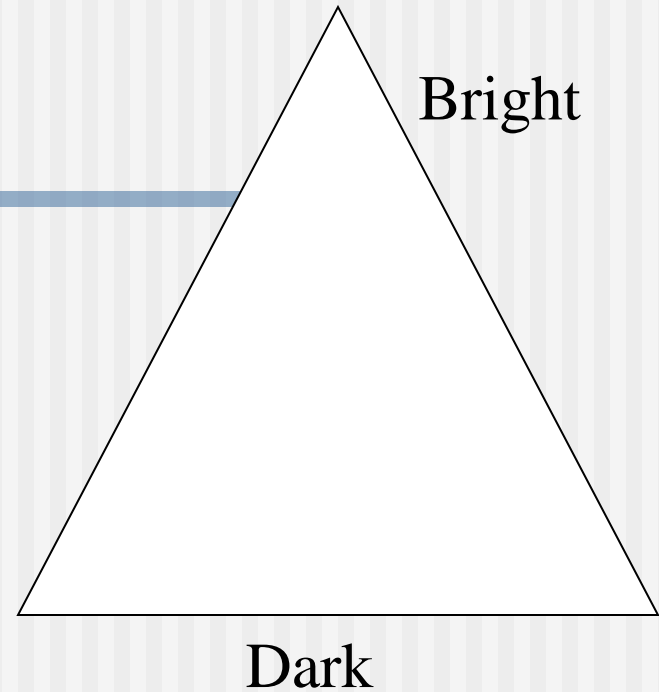

Triangle on Music Stand

- Two Beater technique
- Intricate Rhythms
- Fast Rhythms
- Rolls

- Muffling
 - Fingers

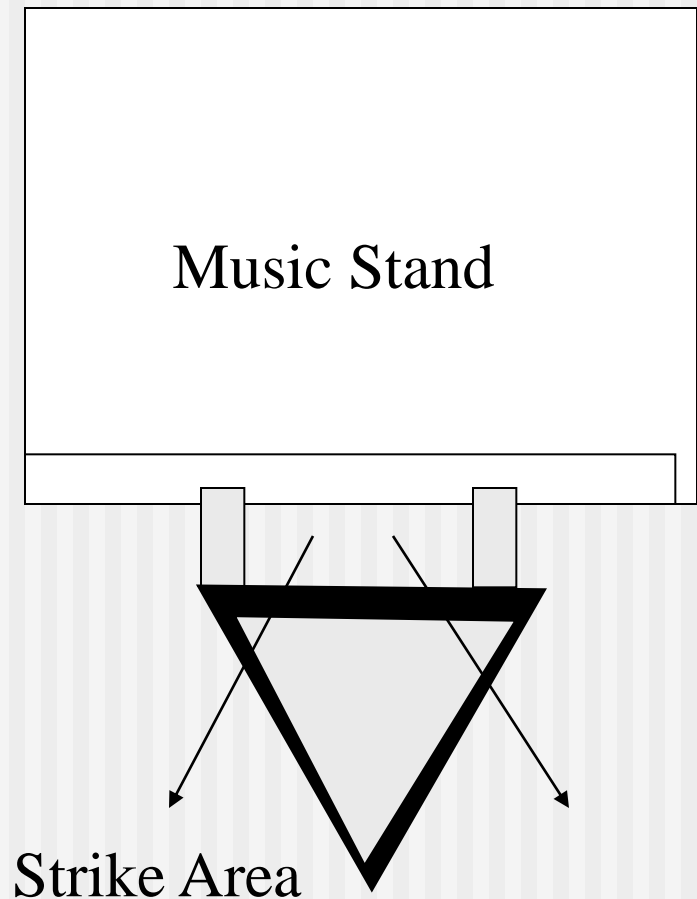

Wood Blocks

- Wood Block
 - Holding position
 - Hand
 - One Hand
 - Trap Table
 - Two Hands
 - Med to Hard Rubber Mallet
 - Striking area
 - Makers
 - Black Swamp
 - Vaughncraft

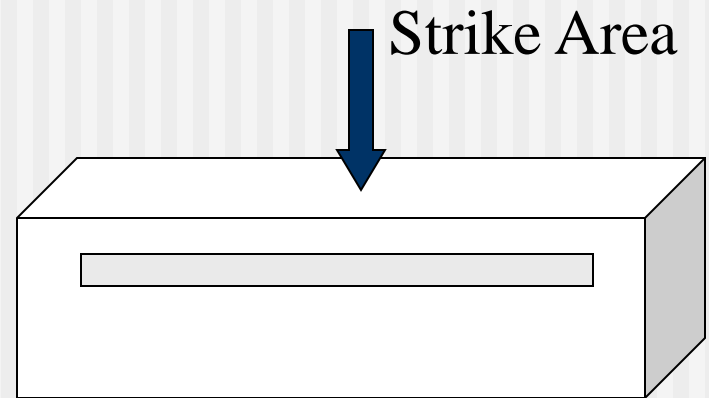

Cup Hand Underneath
or place on soft padded
towel or pad to play
with two mallets for
fast passages.

Claves / Maracas

- Claves (Rosewood)
 - Holding position
 - Best sound production
- Maracas
 - Technique
 - Rolls

Cup bottom clave in hand

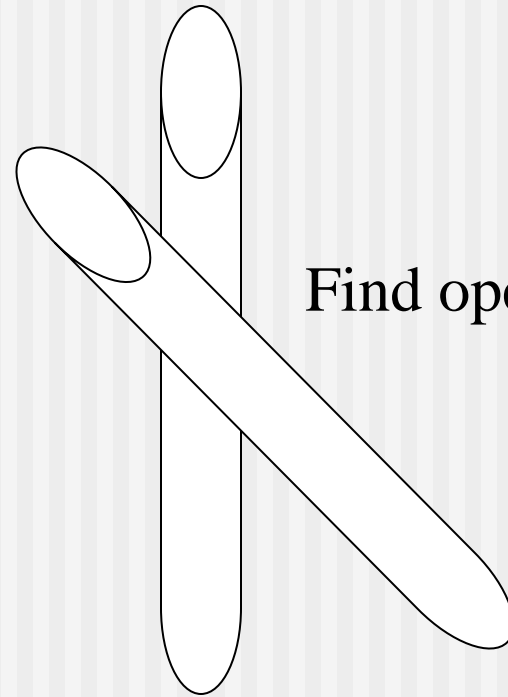

Find open tones

Castanets

- Types
 - Hand – for dancers, not percussion
 - Paddle – general performance
 - Machine – logistical time factor
- Made from Plastic, Rosewood, Ebony
- Technique
 - Need Chair to rest knee
- Makers
 - Black Swamp
 - Grover

Fast / Loud Technique

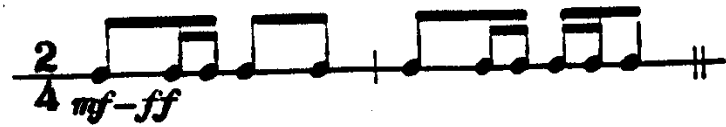

Machine Castanets

- Castanet Pair Mounted on a Block
- Use two fingers grouped together to play more intricate, faster and accurate rhythms

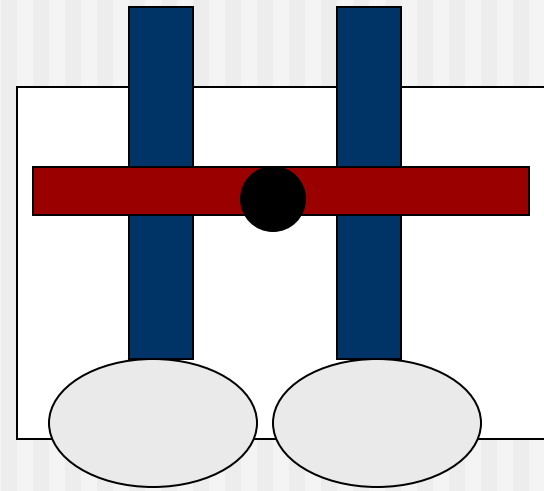

Sleigh Bells

- Hold in left hand with handle up and bells facing to the ground
- Strike the handle of the bells with fist of the right hand

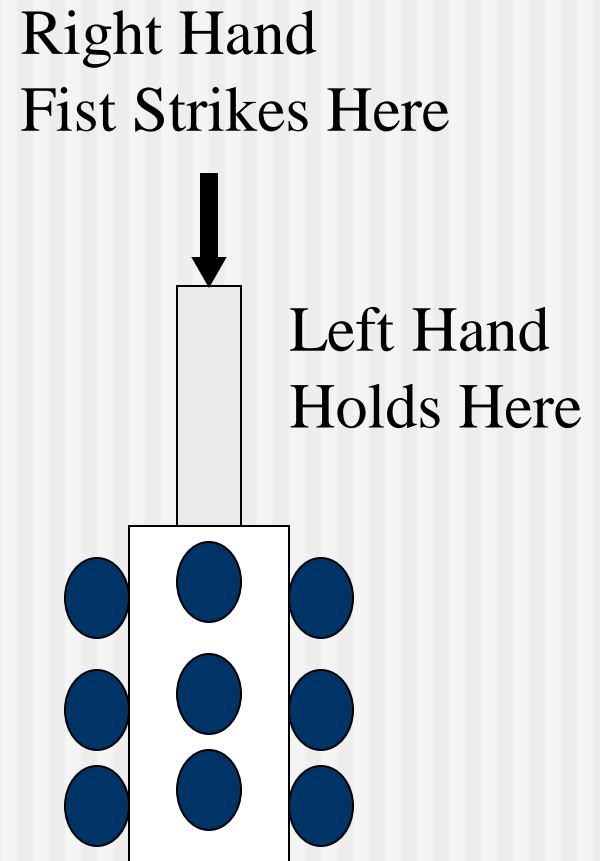

Percussion Accessories

- Vibra-Slap
- Guiro
- Slap stick
- Cabasa / Afuce
- Shakers

Jazz on the Drum Set

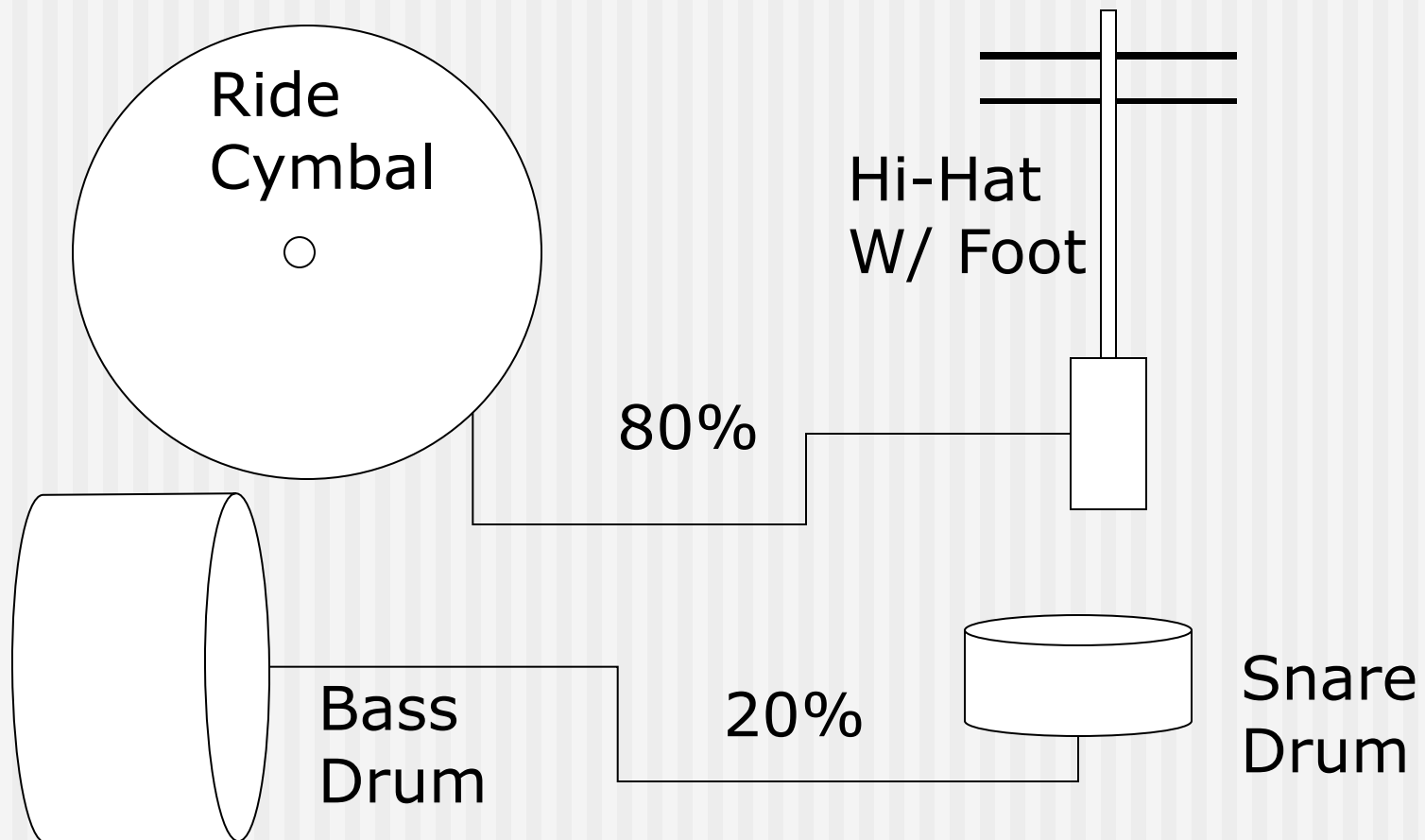

Swing Beat

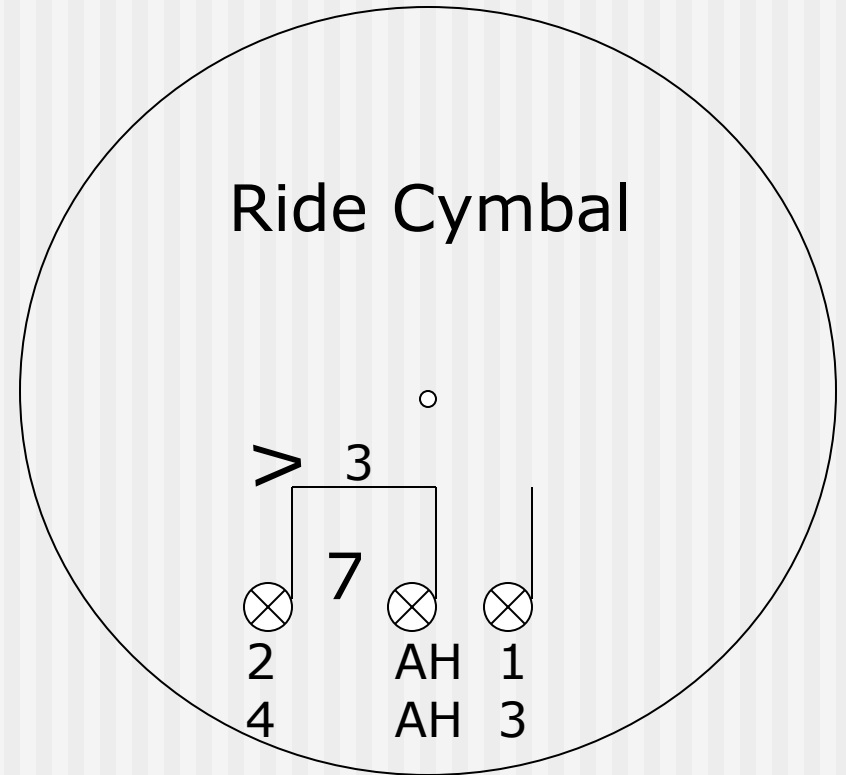
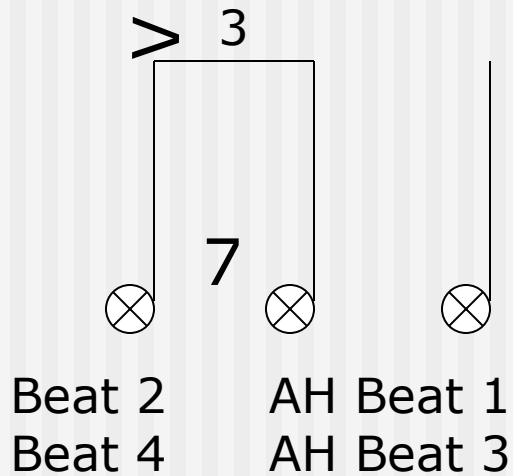

Jazz Beats

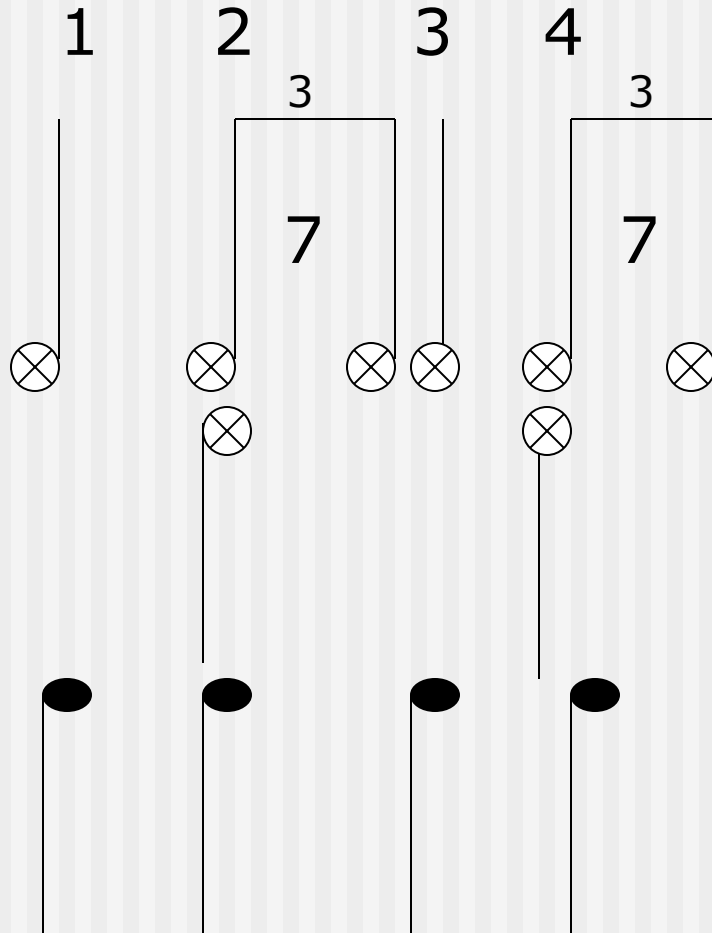

Ride Cymbal Pattern

Hi-Hat w/ Foot

Light Bass Drum
“Feathering”

Rock on the Drum Set

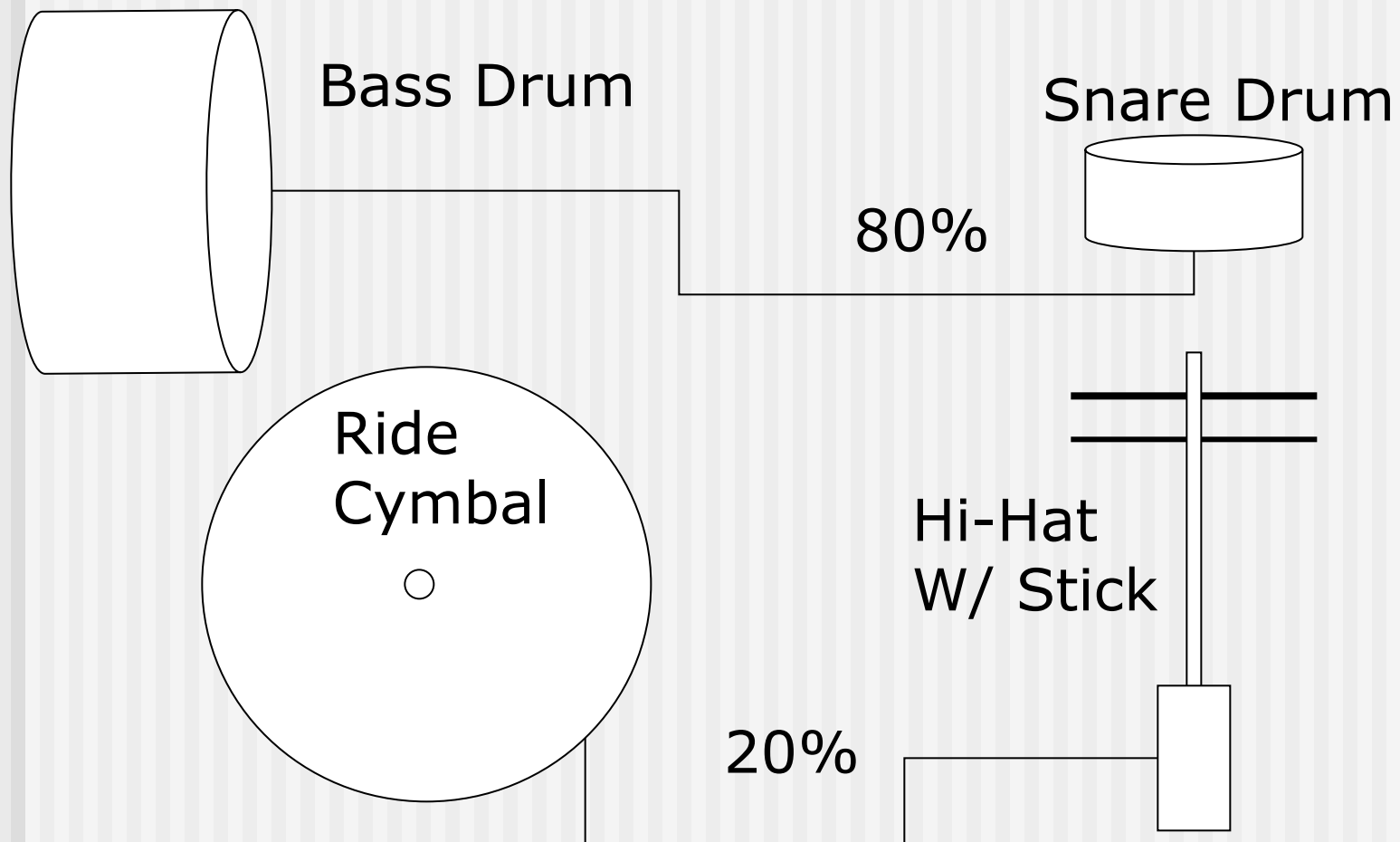

Timpani



Timpani Tuning Range

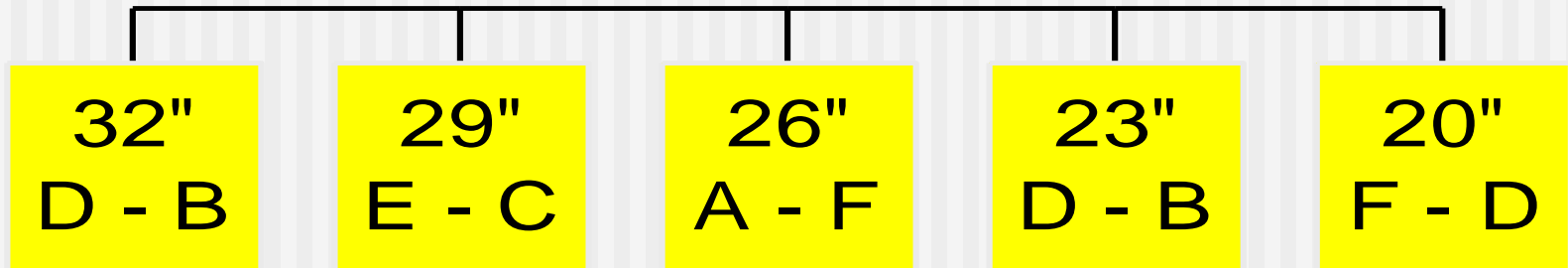
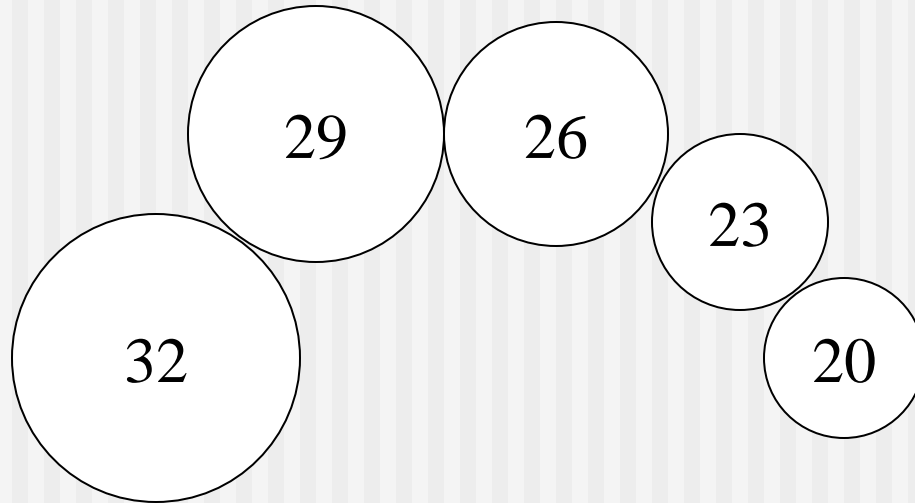

Timpani Parts



Timp Bowls

- Polished Copper
 - Bright tone and great projection
- Hammered Copper
 - Darker, more focused sound
- Fiberglass
 - Painted a copper color, satin finish
 - Good sound

Internal Linkage

Linkage and spider are inside bowl.

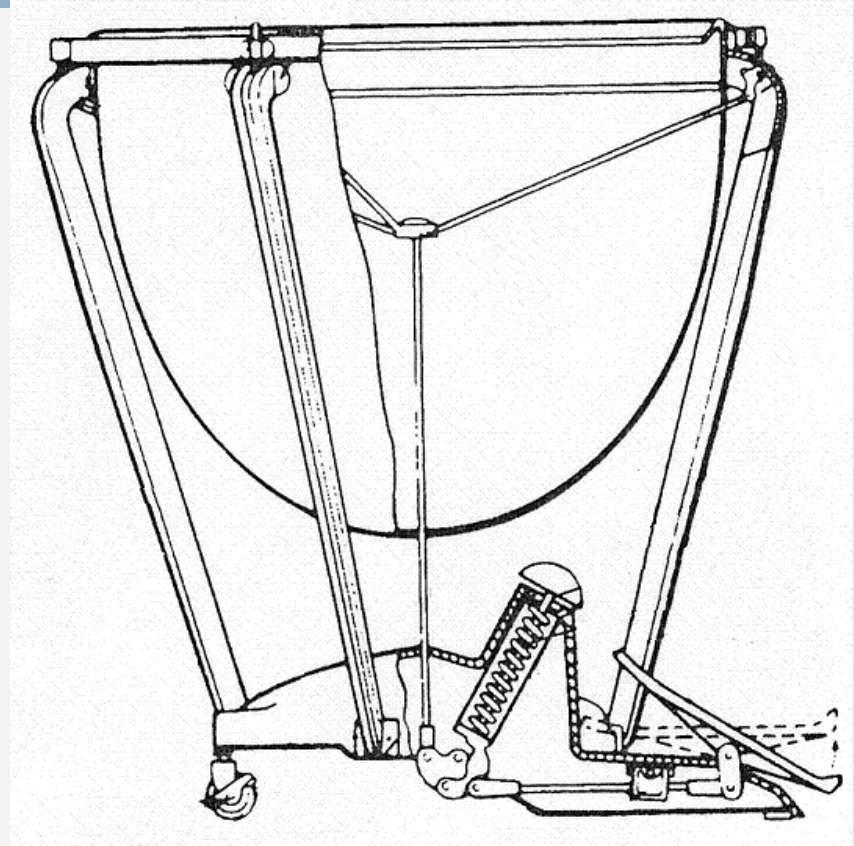

External Linkage

Linkage and spider
outside bowl,
partly hidden in
the struts.
Nothing inside the
bowl.

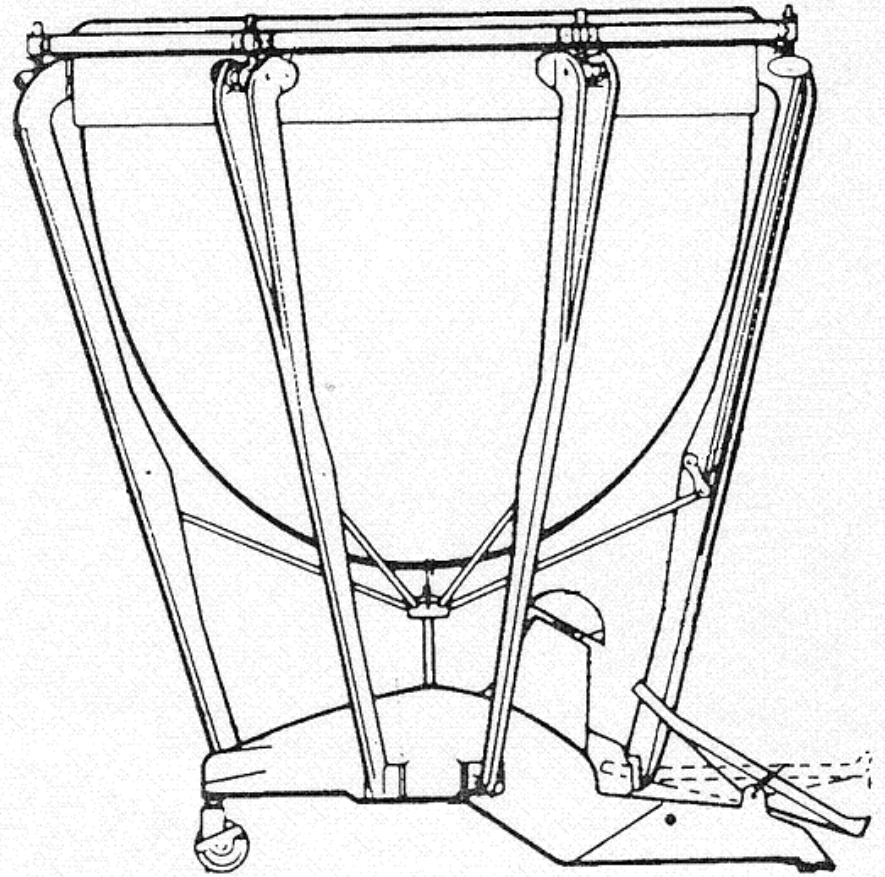

Timpani

- Mallets
 - General (Medium felt)
 - Soft (Soft felt)
 - Staccato (Hard felt)
- Grip
 - German (Like matched grip for snare drum)
 - French (Wrist turned so that thumb is on top)

Timpani

- Striking area
- Stroke
- Rolls
- Dampening
- Tuning
- Balancing a head and pedal

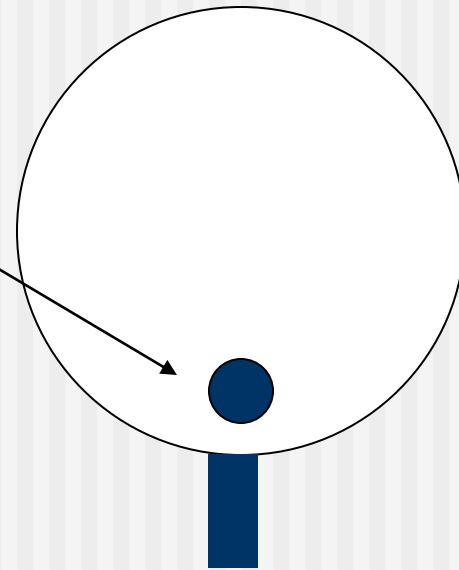

Mallet Percussion

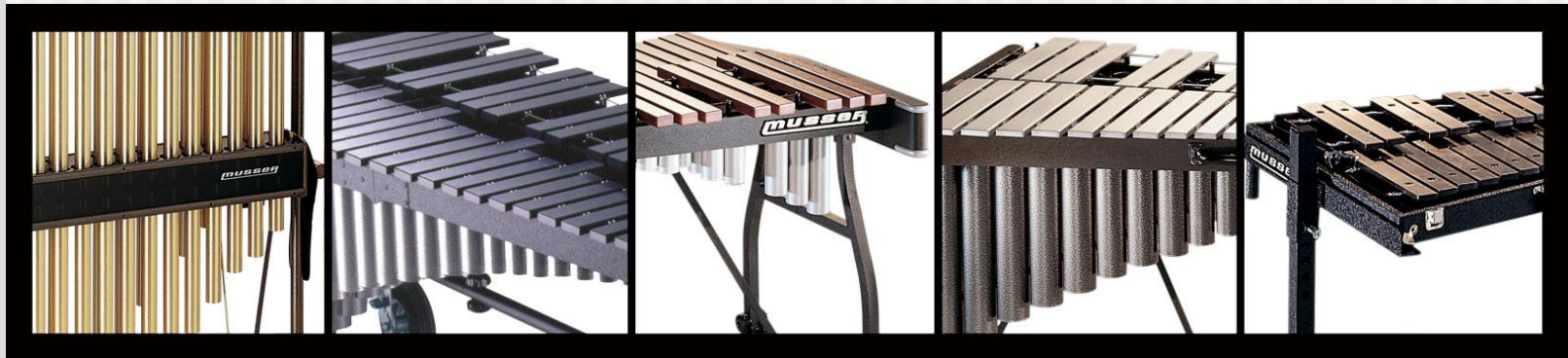

Chimes

Marimba

Xylophone

Vibes

Bells

Concert Frame or Field Cart

Mallet Keyboard Training Camp

- Rosewood Bar
 - Grown in Belize, Central America
 - Selected for tone and resonance
 - Preferred professional bar material
 - For Marimbas and Xylophones
 - Mellow, focused, full bodied tone
 - Weather affects rosewood
 - More likely to crack

Mallet Keyboard Training Camp

- Aluminum Bar
 - Made from extruded aluminum
 - Pro models have a radius on their edge
 - Preferred professional bar material
 - For Vibraphones
 - Mellow tone
 - Anodized in silver or gold
 - Graduated & non-graduated bars
 - Only played with yarn / cord mallets

Mallet Keyboard Training Camp

- Steel Bar
 - Made from extruded heat treated steel
 - Special formula
 - For orchestra bells only
 - Bright piercing tone
 - Polished and lacquered
 - Non-graduated bars
 - Only played with hard rubber, brass or synthetic mallets

Nodal Points

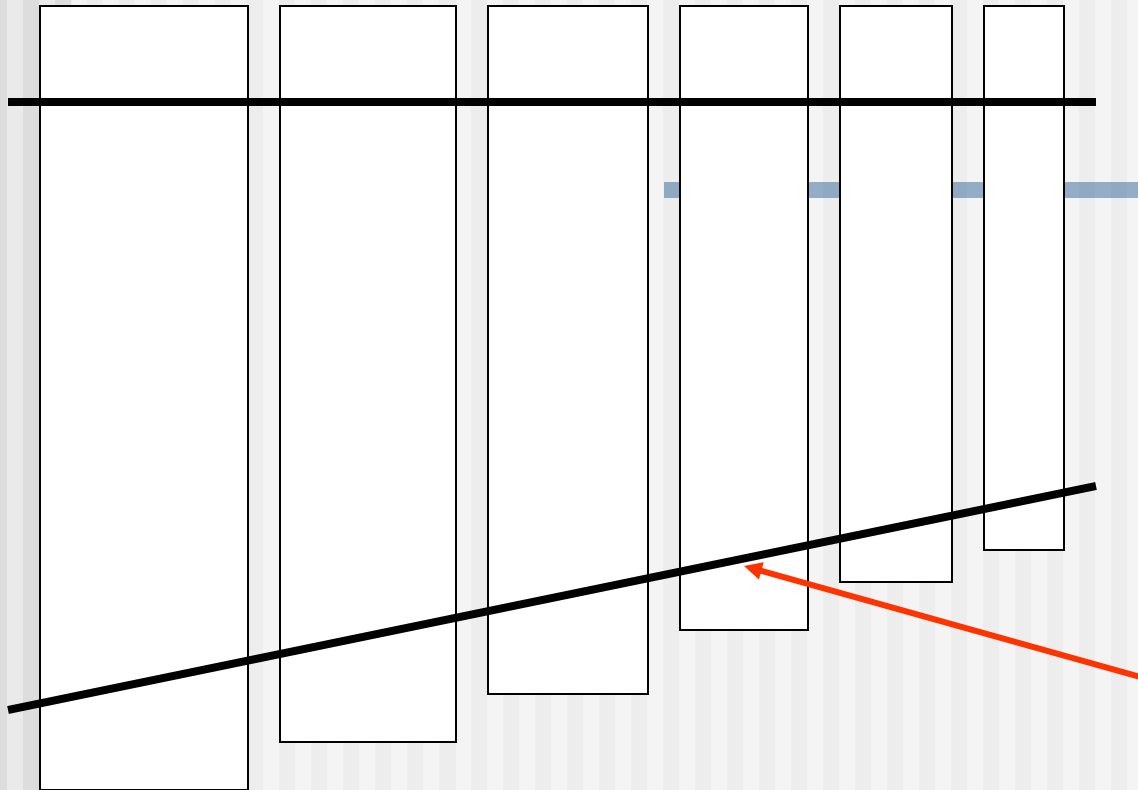

The nodal point is the area of least resonance and where the bar is dilled for the bar cord to pass through to suspend the bar on the rails.

Parachute Cord

Graduated Bars

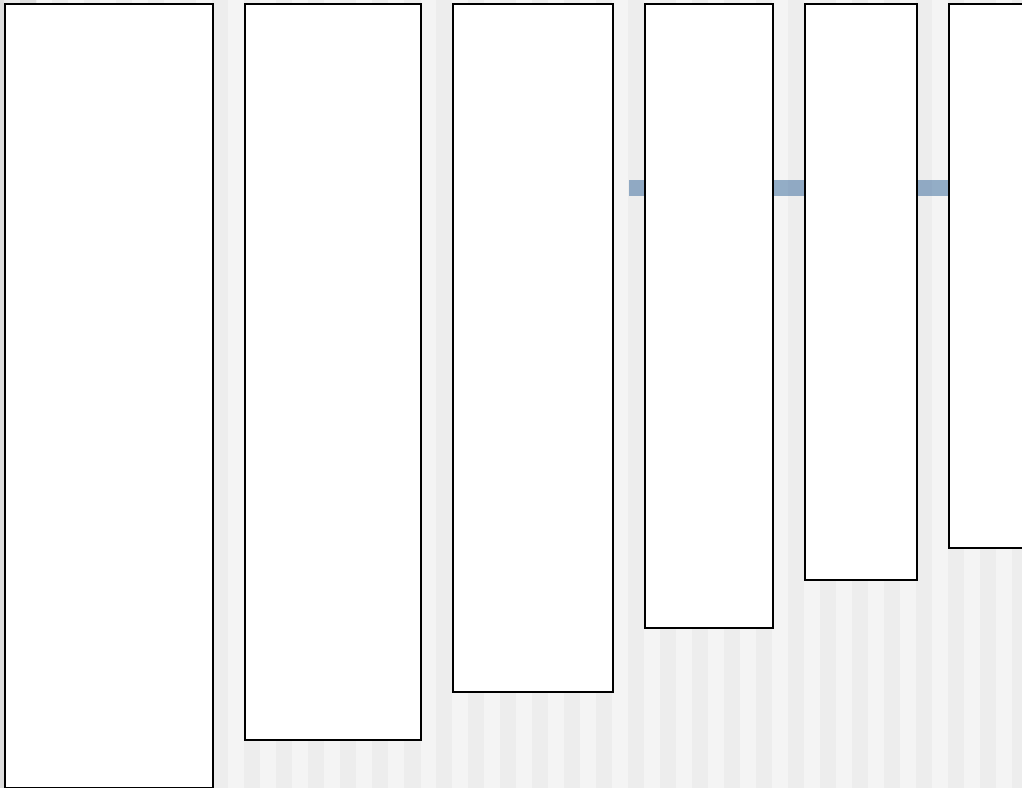

Graduated bars are wide on the low end, gradually becoming narrower as the bar length and pitch goes high.

Value of graduated bars – full deep bodied tone.

Non-Graduated Bars

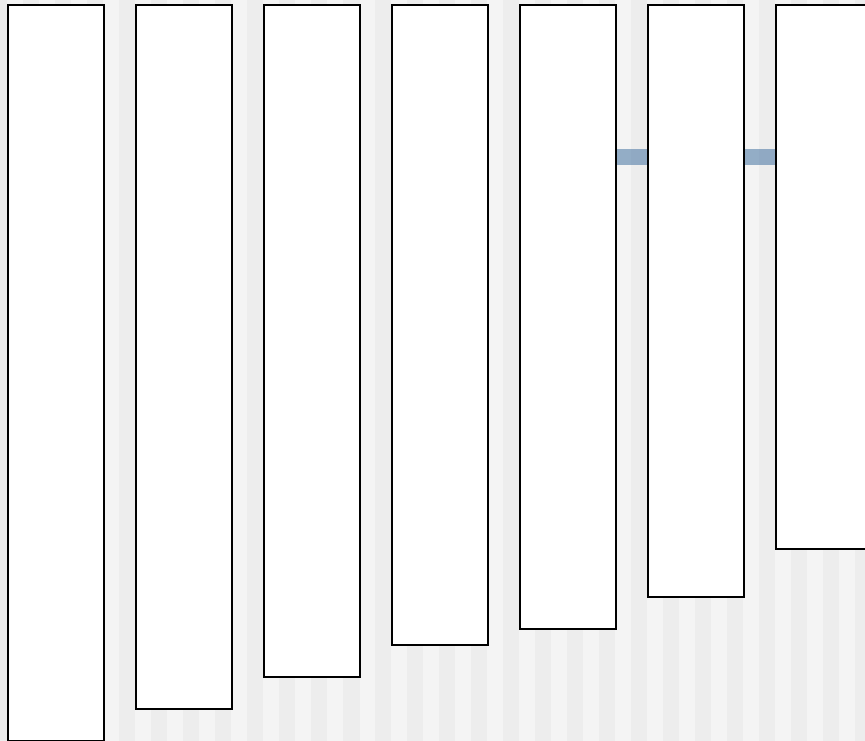

Non-graduated bars are standard on xylos & bells.

On marimbas & vibes they are an economy feature. Sound is less full than a graduated bar, especially on the low end.

Mallet Instrument Resonators

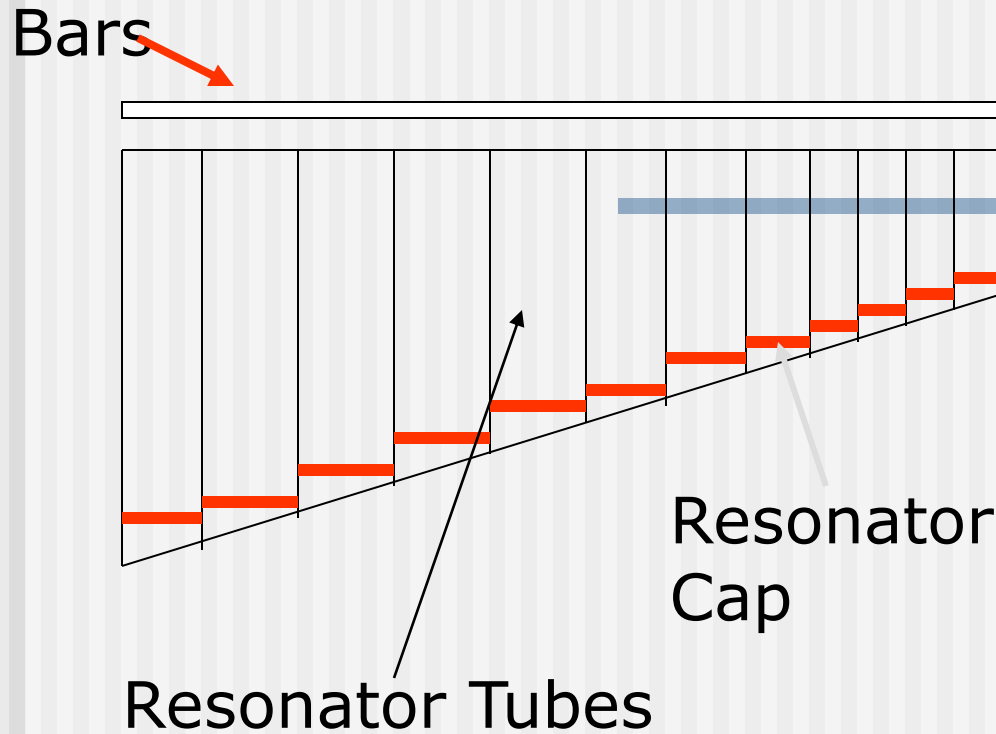

Aluminum tubes that hang vertically underneath the bars. Each tube is tuned to the bar above it by placement of a cap inside the tube that optimizes the resonance and acts like an amplifier.

Straight In-Line Resonators

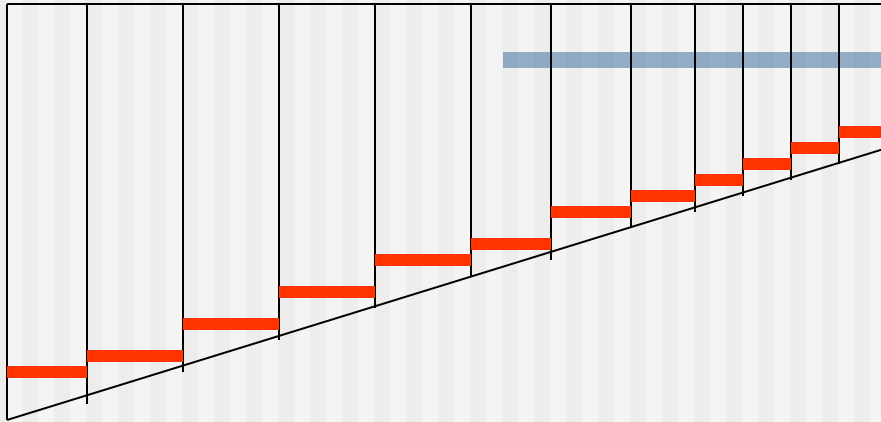

Standard resonator design. The longer the resonator tube – the deeper the pitch and longer the tone.

All natural note bars have In-Line Resonators

Arched Resonators

Functional

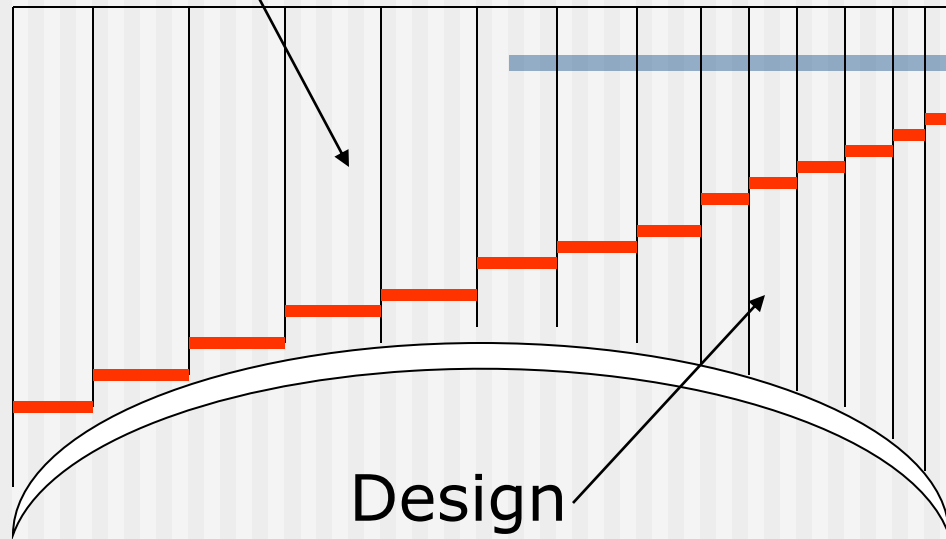

Arched resonators are for cosmetics only. Resonator caps are still set in-line. Only on the sharp scale of specific mallet instruments.

Musser Mallet Percussion

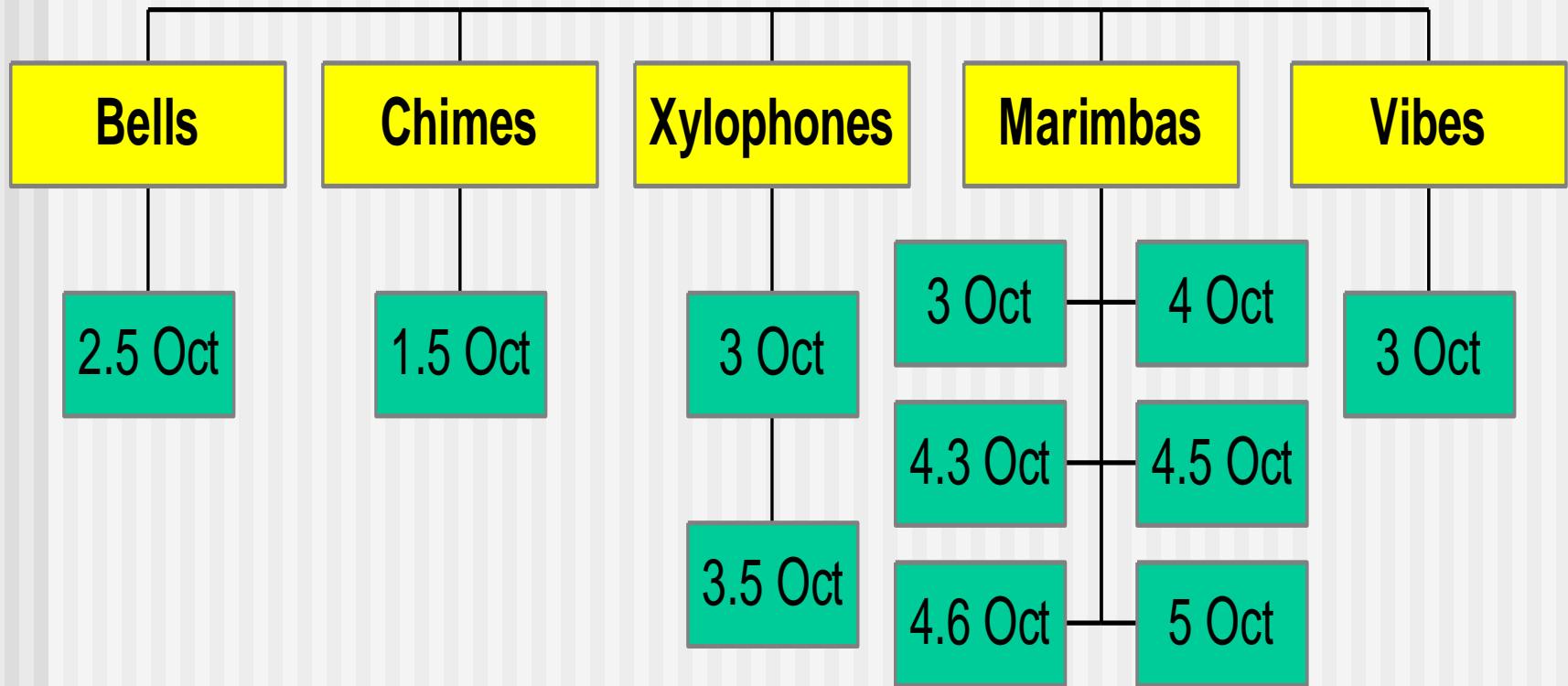

Bell Stand Options



Marimba on Field Cart



Middle School

Snare Drum 5x14"

Concert Snare
Stand

2B / SD1
Drumsticks

Wire Brushes

Concert Bass 14x28" w/ Stand

Tilting Bass
Stand

Bass Drum
Mallet

Orchestra Bells 2.5 Oct. Aluminum

Bell Stand

Hard Gray
Rubber Mallets

Middle School

Timpani
26" 29"

Timpani
Mallets

Timp Tuning
Key

Xylophone
3 / 3.5 Oct.
Kelon

Hard Gray
Rubber Mallets

Medium Blue
Rubber Mallets

Marimba
4 / 4.3 Oct.
Kelon

Medium Blue
Yarn Mallets

Soft Yellow
Rubber Mallets

Middle School

Suspended Cymbal Stand

Cymbal Cradle

Soft Yellow
Yarn Mallets

Chimes 1.5 Oct. Brass

Rawhide
Chime Mallets

Vibraphone 3 Oct. Silver

Fiberglass
Handle
Medium Cord
Mallets

Fiberglass
Handle Soft
Cord Mallets

Middle School

Wooden Accessories

Synthetic
Temple Blocks

Large Wood
Blocks

Claves

Slapstick

Shaken Accessories

Maracas

Shaker

Dbl Row 10"
Tambourine

Metallic Accessories

Triangle / clip /
beaters

Timbale
Cowbell

Sleigh Bells

High School

Snare Drum 6.5x14"

Concert Snare
Stand

Coated
White 14"
Batter Head

SD1
Drumsticks

Concert Bass Drum 18x36"

Suspended
Bass Stand

General Bass
Mallet

Roller Bass
Mallets

Orchestra Bells 2.5 Oct. Steel

Bell Cart

Hard Gray
Rubber Mallets

Brass Mallets

High School

Marimba
4.3 Oct. Kelon

Yarn Marimba
Mallets
(set of 4)

Marimba
Cover

Vibraphone
3 Oct. Silver

Cord Vibes
Mallets
(set of 4)

Vibe Cover

Chimes
1.5 Oct.

Rawhide
Chime Mallets

Chime Cover

High School

Xylophone 3.5 Oct.

Hard Gray
Rubber Mallets

Full Padded
Cover

Timpani Copper

Set of 4
Timpani
mallets

Padded Covers

Concert Toms Set of 4 (Mid)

Timbales w/
Stand

Bongos w/
Stand

Recreational Percussion

- Hand Drums
- Shaken / Wooden / Metallic
- Kitchen / Garage Drums
- Fun – For everyone – Interactive
- Therapeutic – Health / Stress / Team Building
- Drum Circles

Drumheads

Marching

Snare Drum
Dotted
Kevlar

Bass Drum
Smooth White

Multi Toms
Heavy Clear
Pin Stripe

Concert

Snare Drum
Medium
Coated

Toms
Medium Clear

Bass Drums
Smooth White
Fiberskyn

Drum Set

Snare Drum
Medium /
Heavy Coated

Toms
Heavy Clear

Bass Drum
Heavy Clear
Muffle Ring

Drumsticks

Marching

3S

MS1

Concert

2B

SD1

Drum Set

Wood Tip
Nylon Tip

7A Jazz

5A
General

5B Rock

Drum Mallets

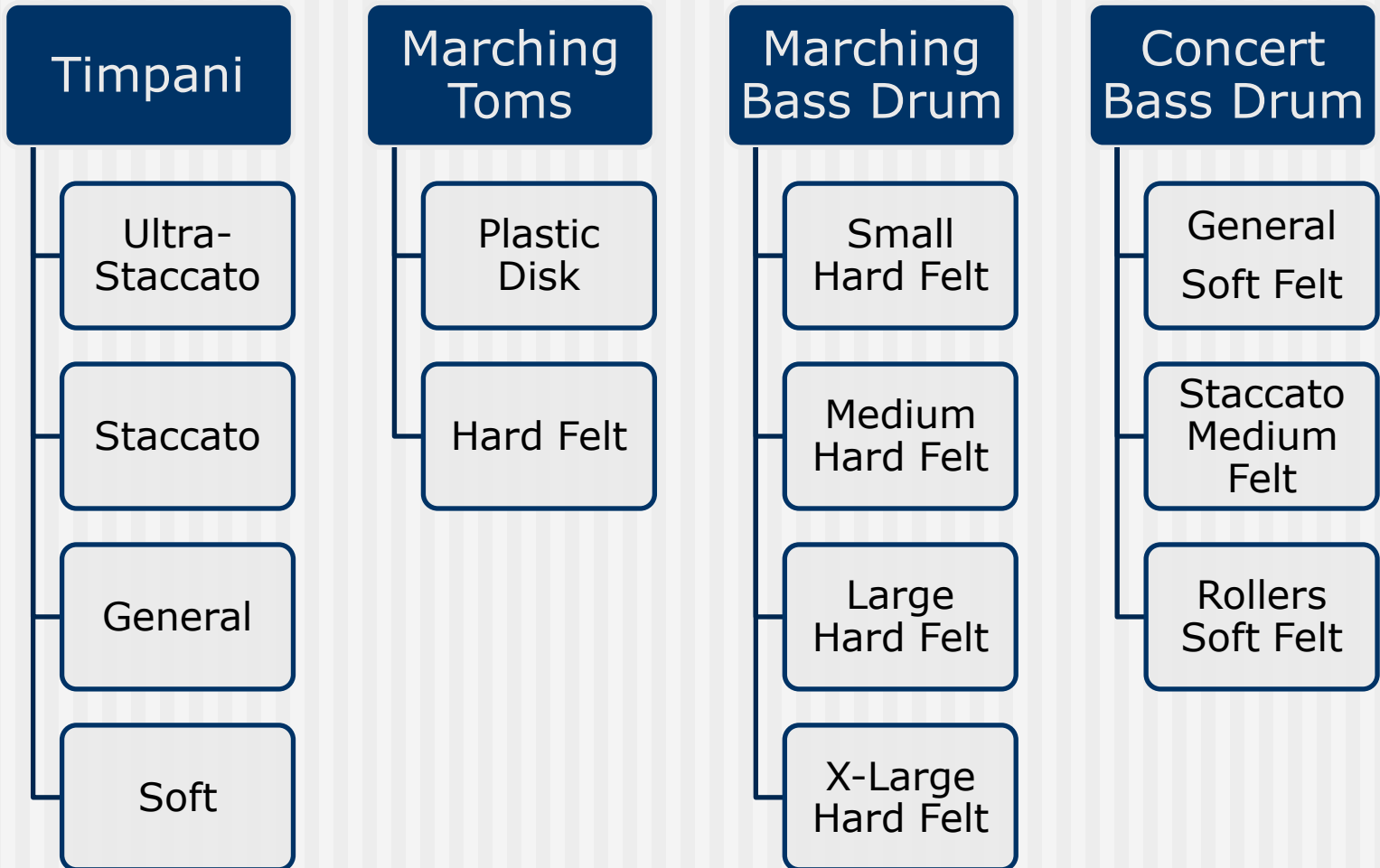

Mallet Keyboard Mallets

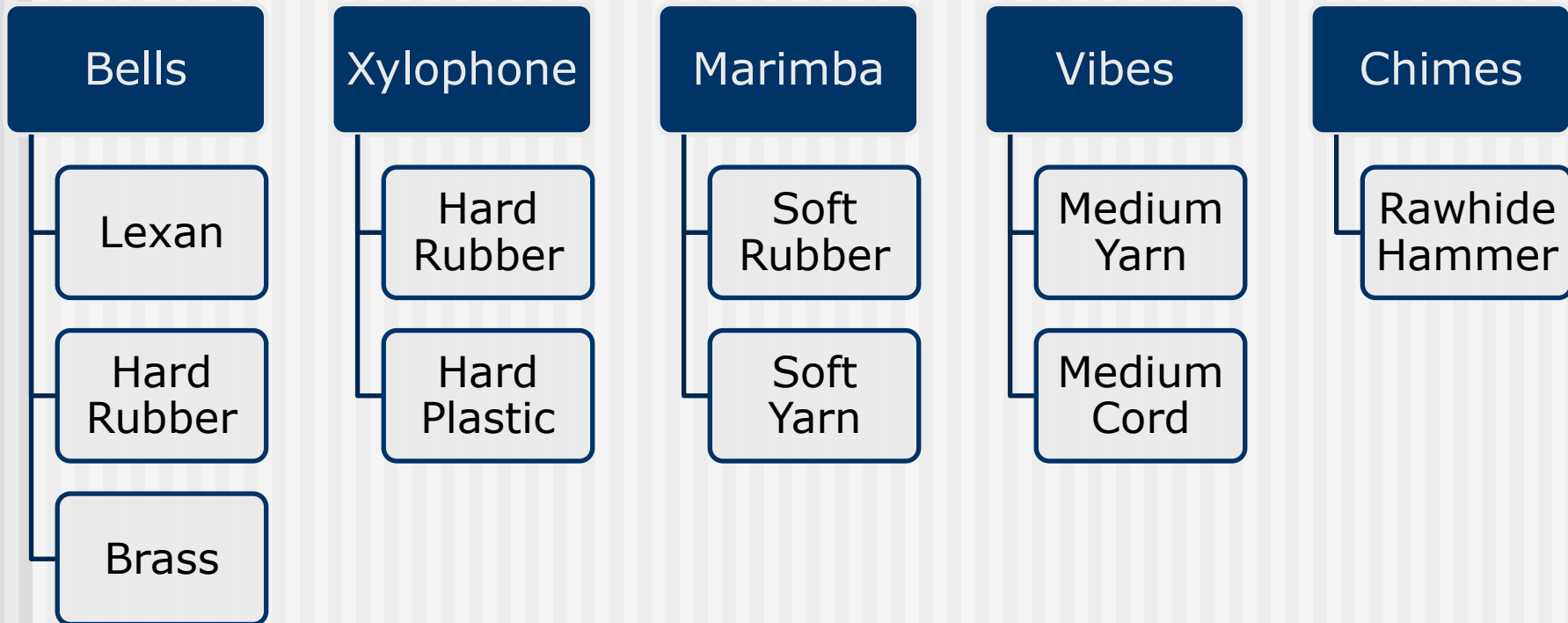

Keyboard Mallets handles made of Rattan, Birch, & Fiberglass

Percussion Accessories

Tambourine

Triangles

**Temple
Blocks**

**Wood
Blocks**

Cow Bells

Whistles

Castanets

Sleigh Bells

Maracas

Shakers

Claves

Ratchet

Slap Stick

Guiro

Cabasa

Trap Tables

Drum Keys

Vibraslap

**Cymbal
Sleeve**

**Felt
Washers**

Thank You

Jim Catalano

Jcatalano@ludwig-drums.com